

Electronic temperature switch

Typ TSD-30



Art. No. 148331

Type No. TSD30.2.P.IO.4.12.100



Exemplary illustration

The successful design and the excellent functionality of the WIKA switch family were already confirmed by winning the "iF product design award" for the model PSD-30 pressure switch.

The robust LED display has been designed using 9 mm high characters (the largest possible) and with a slight incline in order to make reading the temperature as easy as possible from a long way off. The use of a 14-segment display ensures a clear display and readability of letters.

The 3-key operation makes simple, intuitive menu navigation possible, with no need for additional assistance. The menu navigation is designed in accordance with the latest VDMA standard. The control keys have been designed as large as possible and are arranged ergonomically to ensure fast and easy adjustments. Operation without any additional assistance is made easier through the tactile feedback.

The installation of the model TSD-30 temperature switch can be flexibly adapted to the individual mounting situation. Due to the almost unlimited rotation of the display and case by more than 300°, the display can be adjusted independently of the electrical connection. The display can thus always be aligned to face the operator, and the M12x1 connection positioned to suit the desired cable routing.

During development of the WIKA switch family a high value was placed on a robust design and the selection of appropriate materials suited to machine building applications. For this reason the case and the threaded connection of the electrical connector are made from stainless steel. Overwinding or tearing off the connector is therefore virtually impossible.

Technical data

WIKA type	TSD-30
Housing	CrNi steel 1.4301
Indicating range	-20 to 80 °C
Ambient temperature	-20 to 80 °C
Protection IP	IP 65 and IP 67
Accuracy	≤ 0.5 % FS
Output signal	2 switching outputs (IO link/PNP + PNP)
Thread	G 1/2 AG
Wetted parts	CrNi steel 1.4571
Electrical connection	circular plug-in connector M12x1, 4-wire
Display head material	PC + ABS blend
IO-Link	1.1

Technical data

Probe length	100 mm
Power supply	DC 15 - 35 V

Other special versions with different output signals, process connections, sensors and probe lengths can be individually selected for the respective application and are available on request.

Commercial data

Customs tariff number	90251900
Country of origin	DE
eCl@ss 5.1.4	27140101
eCl@ss 9.0	27140101
UNSPSC_Code_v190501	41112209
UNSPSC_CodeDesc_v190501	Electronic temperature switches

Electronic temperature switch with display Model TSD-30

WIKA data sheet TE 67.03



for further approvals
see page 6



Applications

- Machine tools
- Hydraulic power packs
- Cooling and lubrication systems
- Machine building

Special features

- Easily readable, robust display
- Intuitive and fast setup
- Easy and flexible mounting configurations



Electronic temperature switch with display Model TSD-30

Description

Award-winning in design and functionality

The successful design and the excellent functionality of the WIKA switch family were already confirmed by winning the "iF product design award" for the model PSD-30 pressure switch.

The robust LED display has been designed using 9 mm high characters (the largest possible) and with a slight incline in order to make reading the temperature as easy as possible from a long way off. The use of a 14-segment display ensures a clear display and readability of letters.

The 3-key operation makes simple, intuitive menu navigation possible, with no need for additional assistance. The menu navigation is designed in accordance with the latest VDMA standard. The VDMA standard for fluid sensors (24574-2, part 2 temperature switches) has the aim of considerably simplifying the use of temperature switches by standardising menu navigation and display.

The control keys have been designed as large as possible and are arranged ergonomically to ensure fast and easy adjustments. Operation without any additional assistance is made easier through the tactile feedback.

Customised installation

The installation of the model TSD-30 temperature switch can be flexibly adapted to the individual mounting situation. Due to the almost unlimited rotation of the display and case by more than 300°, the display can be adjusted independently of the electrical connection. The display can thus always be aligned to face the operator, and the M12 x 1 connection positioned to suit the desired cable routing.

IO-Link

With the optional output signal in accordance with the IO-Link communication standard, the TSD-30 allows a fast integration into modern automation systems. IO-Link offers an even faster installation, parameterisation and higher functionality of the TSD-30.

WIKA data sheet TE 67.03 · 10/2019

Page 1 of 7

Data sheets showing similar products:
Electronic pressure switch with display; model PSD-4; data sheet PE 81.86
Electronic level switch with display; model LSD-30; data sheet LM 40.01
Electronic flow switch with display; model FSD-30; data sheet FL 80.01



Measuring ranges

Selectable versions		
Temperature	°C	°F
Standard	-20 ... +80	-4 ... +176
Option 1 ¹⁾²⁾	-20 ... +120	-4 ... +248
Option 2 ¹⁾²⁾	0 ... +150	+32 ... +302

1) Only for process connections with compression fitting.
2) Installation instructions under "Operating conditions" must be observed.

Display

14-segment LED, red, 4-digit, 9 mm [0.35 in] character size
Display can be rotated electronically through 180°
Update: 200 ms

Output signal

	Selectable versions		Analogue signal
	Switching output		
	SP1	SP2	
Option 1	PNP	-	4 ... 20 mA (3-wire)
Option 2	PNP	-	DC 0 ... 10 V (3-wire)
Option 3	PNP	PNP	-
Option 4	PNP	PNP	4 ... 20 mA (3-wire)
Option 5	PNP	PNP	DC 0 ... 10 V (3-wire)

Optionally also available with an NPN instead of a PNP switching output.

IO-Link, revision 1.1 (option)

IO-Link is optionally available for all output signals.
With the IO-Link option, switching output SP1 is always PNP

Switching thresholds

Switch point 1 and switch point 2 are individually adjustable

Switching functions

Normally open, normally closed, window, hysteresis (freely adjustable)

Switching voltage

Supply voltage - 1 V

Switching current

- without IO-Link: max. 250 mA
- with IO-Link: SP1 max. 100 mA
SP2 max. 250 mA

Adjustment accuracy

≤ 0.5 % of span

Adjustment of zero point offset

±3 % of span

Scaling

Zero point: 0 ... 25 % of span
Full scale: 75 ... 100 % of span

Load

Analogue signal 4 ... 20 mA: ≤ 0.5 kΩ
Analogue signal DC 0 ... 10 V: > 10 kΩ

Service life

100 million switching cycles

Voltage supply

Supply voltage U_s

DC 15 ... 35 V

Current consumption

Switching outputs with

- Analogue signal 4 ... 20 mA: 70 mA
- Analogue signal DC 0 ... 10 V: 45 mA
- without analogue signal: 45 mA

IO-Link option causes a deviating current consumption

Total current consumption

- without IO-Link: max. 600 mA including switching current
- with IO-Link: max. 450 mA including switching current

Accuracy specifications

Analogue signal

≤ ±0.5 % of span + temperature sensor error

Switching output

≤ ±0.8 % of span + temperature sensor error

Display

≤ ±(0.8 % of span + temperature sensor error) ±1 digit

Temperature sensor error

For °C: ±(0.15 K + 0.002 | t |)

For °F: ± [1.8*(0.15 + 0.002 (t - 32) / 1.8)]

| t | is the numerical value of the temperature without consideration of the sign.

The actually achievable accuracy is significantly determined by the mounting situation (immersion depth, probe length, operating conditions). This is especially the case for large temperature gradients between the environment and the medium.

Probe

Probe length (F)

Mounting thread

Parallel thread

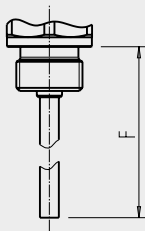

Tapered thread

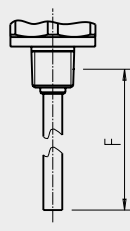

F	25	50	100	150	200	250	300	350
mm	25	50	100	150	200	250	300	350
in	0.98	1.97	3.94	5.91	7.87	9.84	11.81	13.8

Compression fitting

Parallel thread

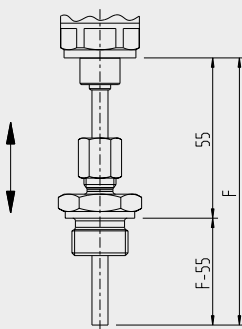

Tapered thread

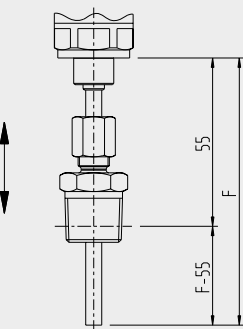

F	100	150	200	250	300	350
mm	100	150	200	250	300	350
in	3.94	5.91	7.87	9.84	11.81	13.8

Response time

T05 < 5 s (per DIN EN 60751)

T09 < 10 s (per DIN EN 60751)

Static operating pressure

max. 150 bar [2,175 psi]

When using a compression fitting:

max. 50 bar [max. 725 psi]

Operating conditions

Permissible temperature ranges

Medium: see measuring ranges

Ambient: -20 ... +80 °C [-4 ... +176 °F]¹⁾

Storage: -20 ... +80 °C [-4 ... +176 °F]

1) At medium temperatures above 80 °C [176 °F] the permissible ambient temperature is limited to -20 ... +40 °C [-4 ... +104 °F]. In this case, the process connection has to be designed with a compression fitting.

At high medium or ambient temperatures, ensure by suitable measures that the instrument case temperature does not exceed 80 °C [176 °F] in continuous operation (the temperature is measured at the hexagon of the process connection).

Air humidity

45 ... 75 % r. h.

Vibration resistance

Probe length F ≤ 150 mm [5.91 in]:

6 g (IEC 60068-2-6, under resonance)

Probe length F ≥ 250 mm [9.84 in]:

2 g (IEC 60068-2-6, under resonance)

Shock resistance

50 g (IEC 60068-2-27, mechanical)

Ingress protection per IEC/EN 60529

IP65 and IP67

The stated ingress protection only applies when plugged in using mating connectors that have the appropriate ingress protection.

Mounting position

as required

Reference conditions

Temperature:	15 ... 25 °C [59 ... 77 °F]
Atmospheric pressure:	950 ... 1,050 mbar [13.78 ... 15.23 psi]
Air humidity:	45 ... 75 % r. h.
Nominal position:	Process connection lower mount
Supply voltage:	DC 24 V
Load:	see "Output signal"

Materials

Wetted parts

Probe:	Stainless steel 1.4571
--------	------------------------

Non-wetted parts

Case:	Stainless steel
Keyboard:	TPE-E
Display window:	PC
Display head:	PC + ABS blend

Process connections

Selectable versions	
Standard	Thread
DIN EN ISO 1179-2 (parallel thread)	G ¼ A
	G ½ A
DIN 3852-A (parallel thread)	G ¼ A with compression fitting
	G ½ A with compression fitting
ANSI / ASME B1.20.1 (tapered thread)	¼ NPT
	¼ NPT with compression fitting
	½ NPT
	½ NPT with compression fitting

Sealings

Selectable versions		
Connection per	Sealing material	
DIN EN ISO 1179-2 (parallel thread)	Standard	NBR
	Option	FPM/FKM
DIN 3852-A (parallel thread)	Standard	Copper

Electrical connections

Connections

- Circular connector M12 x 1 (4-pin)
- Circular connector M12 x 1 (5-pin) ¹⁾

1) Only for version with two switching outputs and additional analogue signal

Electrical safety

Short-circuit resistance:	S+ / SP1 / SP2 vs. U-
Reverse polarity protection:	U+ vs. U-
Insulation voltage:	DC 500 V
Overvoltage protection:	DC 40 V

Connection diagrams

Circular connector M12 x 1 (4-pin)

	U+	1
	U-	3
	S+	2
	SP1 / C	4
	SP2	2

Circular connector M12 x 1 (5-pin)

	U+	1
	U-	3
	S+	5
	SP1 / C	4
	SP2	2

Legend:

U+	Positive supply voltage
U-	Reference potential
SP1	Switching output 1
SP2	Switching output 2
C	Communication with IO-Link
S+	Analogue output

Dimensions in mm [in]

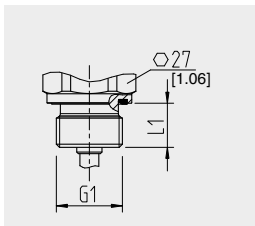
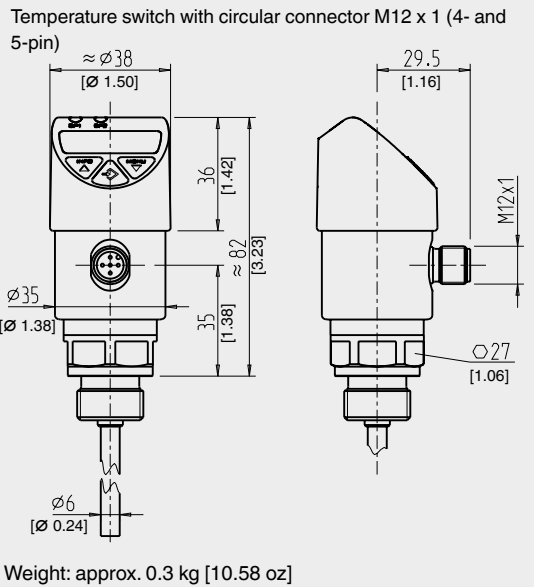

G1	L1
G ¼ A	12 [0.47]
G ½ A	14 [0.55]

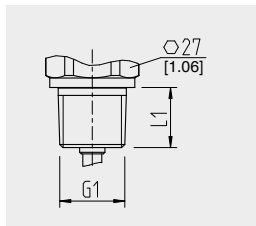

G1	L1
¼ NPT	13 [0.51]
½ NPT	19 [0.75]

Compression fittings

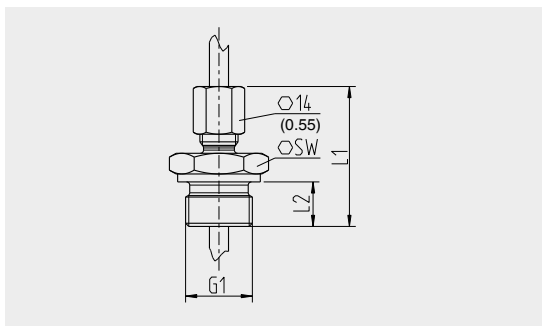



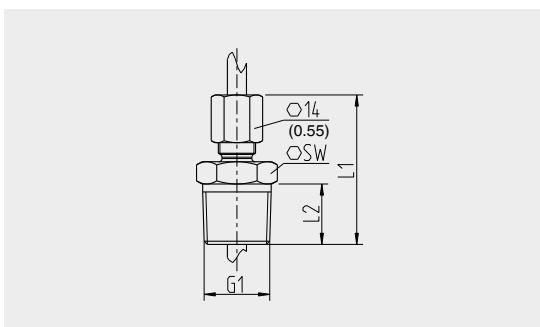



G1	L1	L2	SW
G ¼ A	40 [1.57]	12 [0.47]	19 [0.75]
G ½ A	44 [1.73]	14 [0.55]	27 [1.06]



G1	L1	L2	SW
¼ NPT	41 [1.61]	15.1 [0.59]	17 [0.67]
½ NPT	41 [1.61]	19.7 [0.78]	22 [0.87]

For probe lengths, see page 3.

Approvals



Logo	Description	Country
	EU declaration of conformity <ul style="list-style-type: none"> ■ EMC directive, EN 61326 emission (group 1, class B) and immunity (industrial application) ■ RoHS directive 	European Union
	UL Safety (e.g. electr. safety, overpressure, ...)	USA
	EAC EMC directive	Eurasian Economic Community
	GOST Metrology, measurement technology	Russia
	KazInMetr Metrology, measurement technology	Kazakhstan
-	MTSCHS Permission for commissioning	Kazakhstan
	UkrSEPRO Metrology, measurement technology	Ukraine
-	CRN Safety (e.g. electr. safety, overpressure ...)	Canada

Accessories and spare parts

Compression fittings		
	Description	Order number
	G ¼ A per DIN 3852-A, stainless steel	11160136
	G ½ A per DIN 3852-A, stainless steel	3221555
	¼ NPT, stainless steel	3232905
	½ NPT, stainless steel	14043934

When using compression fittings, a limited static operating pressure of max. 50 bar (max. 725 psi) applies.

Sealings		
	Description	Order number
	NBR profile sealing G ¼ A DIN EN ISO 1179-2	1537857
	FPM/FKM profile sealing G ¼ A DIN EN ISO 1179-2	1576534
	NBR profile sealing G ½ A DIN EN ISO 1179-2	1039067
	FPM/FKM profile sealing G ½ A DIN EN ISO 1179-2	1039075

Connectors with moulded cable				
	Description	Temperature range	Cable diameter	Order number
	Straight version, cut to length, 4-pin, 2 m [6.6 ft] PUR cable, UL listed, IP67	-20 ... +80 °C [-4 ... +176 °F]	4.5 mm [0.18 in]	14086880
	Straight version, cut to length, 4-pin, 5 m [16.4 ft] PUR cable, UL listed, IP67	-20 ... +80 °C [-4 ... +176 °F]	4.5 mm [0.18 in]	14086883
	Straight version, cut to length, 4-pin, 10 m [32.8 ft] PUR cable, UL listed, IP67	-20 ... +80 °C [-4 ... +176 °F]	4.5 mm [0.18 in]	14086884
	Straight version, cut to length, 5-pin, 2 m [6.6 ft] PUR cable, UL listed, IP67	-20 ... +80 °C [-4 ... +176 °F]	5.5 mm [0.22 in]	14086886
	Straight version, cut to length, 5-pin, 5 m [16.4 ft] PUR cable, UL listed, IP67	-20 ... +80 °C [-4 ... +176 °F]	5.5 mm [0.22 in]	14086887
	Straight version, cut to length, 5-pin, 10 m [32.8 ft] PUR cable, UL listed, IP67	-20 ... +80 °C [-4 ... +176 °F]	5.5 mm [0.22 in]	14086888
	Angled version, cut to length, 4-pin, 2 m [6.6 ft] PUR cable, UL listed, IP67	-20 ... +80 °C [-4 ... +176 °F]	4.5 mm [0.18 in]	14086889
	Angled version, cut to length, 4-pin, 5 m [16.4 ft] PUR cable, UL listed, IP67	-20 ... +80 °C [-4 ... +176 °F]	4.5 mm [0.18 in]	14086891
	Angled version, cut to length, 4-pin, 10 m [32.8 ft] PUR cable, UL listed, IP67	-20 ... +80 °C [-4 ... +176 °F]	4.5 mm [0.18 in]	14086892
	Angled version, cut to length, 5-pin, 2 m [6.6 ft] PUR cable, UL listed, IP67	-20 ... +80 °C [-4 ... +176 °F]	5.5 mm [0.22 in]	14086893
	Angled version, cut to length, 5-pin, 5 m [16.4 ft] PUR cable, UL listed, IP67	-20 ... +80 °C [-4 ... +176 °F]	5.5 mm [0.22 in]	14086894
	Angled version, cut to length, 5-pin, 10 m [32.8 ft] PUR cable, UL listed, IP67	-20 ... +80 °C [-4 ... +176 °F]	5.5 mm [0.22 in]	14086896

Ordering information

Model / Measuring range / Output signal / Probe length / Process connection / Sealing / Accessories and spare parts

© 2012 WIKA Alexander Wiegand SE & Co. KG, all rights reserved.
The specifications given in this document represent the state of engineering at the time of publishing.
We reserve the right to make modifications to the specifications and materials.

10/2019 EN

WIKA data sheet TE 67.03 · 10/2019

Page 7 of 7



WIKAL Alexander Wiegand SE & Co. KG
Alexander-Wiegand-Straße 30
63911 Klingenberg/Germany
Tel. +49 9372 132-0
Fax +49 9372 132-406
info@wika.de
www.wika.de

Mechanical mounting For WIKA pressure sensors and WIKA pressure switches

WIKA data sheet IN 00.14

Applications

- For fastening and sealing of a WIKA pressure sensor
- For fastening and sealing of a WIKA pressure switch

Versions

- Standard process connections
- Flush process connections
- UHP process connections
- Hygienic process connections

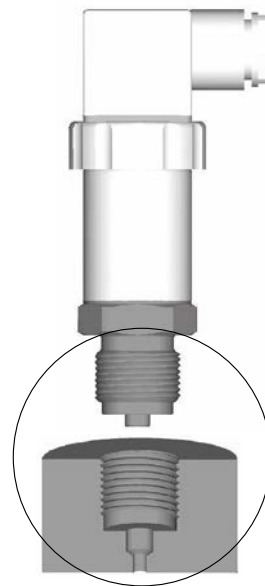

Description

WIKA offers measuring instruments with a variety of process connections in order to meet diverse customer-specific application requirements.

The customer must provide an appropriate tapped hole when installing the pressure sensor or pressure switch. This receives the WIKA pressure measuring sensor or the WIKA pressure switch.

When selecting the appropriate tapped hole, the process connection is just as critical as the thread type of the process connection and the use of the sealing. Process connections are basically divided into standard and flush process connections.

Thread types

WIKA offers process connections with various thread types which are used in numerous applications worldwide.

Types of sealing

Depending on the process connection and the medium, different sealings and sealing materials can be used. Depending on the pressure connection, the location of the sealing varies (→ For notes on sealings, see WIKA data sheet AC 09.08).

You can find further information below. Some tapped holes are available from WIKA as welding sockets. They can be ordered with the specified WIKA order number.

Making the mechanical connection

Requirements for the mounting point

The mounting point must meet the following conditions:

- The sealing faces at the pressure sensor and the measuring locations always have to be clean.
- Remove any protective cap and/or Mylar or protective foil not until shortly before installation.
- Permissible ambient temperatures remain within the performance limits of the measuring instrument. Consider possible restrictions on the ambient temperature range caused by mating connectors used.

Mechanical mounting:

1. Prior to commissioning, the pressure sensor must be subjected to a visual inspection.
Leaking liquid is indicative of damage.
2. Seal the sealing face (→ see “Sealing variants”).
3. At the mounting point, screw the pressure sensor in hand-tight.
4. When screwing in, do not cross the threads.
5. Only ever screw in, or unscrew, the instrument via the spanner flats. Never use the case as a working surface (→ see “Spanner flats”).
6. Tighten the pressure sensor with a torque spanner using the spanner flats.
The correct torque depends on the mounting point (e.g. material and shape).

Only use the pressure sensor if it is in perfect condition with respect to safety.

Only use original accessories. For accessories, see data sheet for the respective pressure sensor or pressure switch.

Additional notes for cooling element

For heat dissipation, the cooling element must not be insulated.

Additional notes for flush process connections

- Check the diaphragm for damage.
- During installation, ensure that the diaphragm is not damaged.

Additional notes for UHP process connections (models WUC-10 and WUC-15)

- For VCR®-compatible connections, the union nut/pressure screw or fitting must be tightened beyond the hand-tight position (depending on the sealings used) using a 1/8 or 1/4 turn.
- For weld-in connections, the flow of argon during the welding process is recommended for cooling.

Rework

1. The zero point must be adjusted, if necessary (→ see operating instructions).
2. Check all mechanical connections (threaded connections, welds) for leak tightness using a suitable test (e.g. helium leak test).
3. Switch the gas flow on and off at least 10 times to remove any particles that may have entered during installation. The flow rate of the gas should correspond to the subsequent process flow.

Additional information on the mounting of G1 hygienic and TRI-CLAMP® process connections

- Never loosen sealed filling screws on the measuring instrument.
- For installation, in accordance with the fitting and flange standards the appropriate fastenings, such as screws, nuts or clamp rings, must be used.
- For flange mounting, only use sealings with a sufficiently large inner diameter and centre them. Contact with the diaphragm leads to measuring deviations.
- When using a welding socket, position this so that the hole for leakage detection points downwards. Weld the welding socket flush with the inner wall of the vessel and grind down. The surface roughness of the ground surfaces must be $Ra \leq 0.8 \mu\text{m}$.
- When using soft or PTFE sealings, observe the instructions of the sealing manufacturer, particularly with regard to tightening torque and load cycles.

Spanner flats

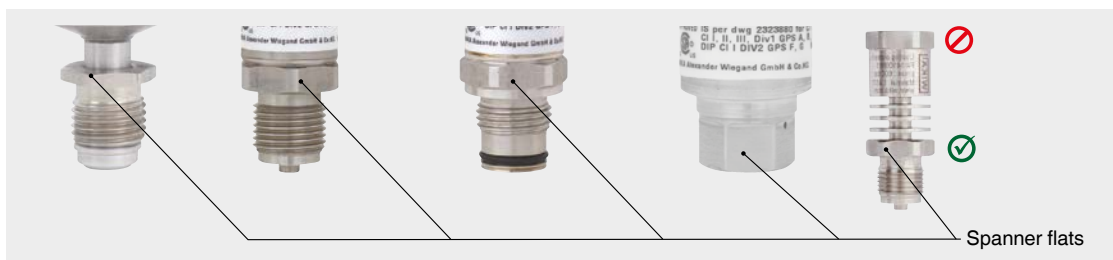

Sealing variants

Parallel threads

For sealing, use flat gaskets, lens-type sealing rings or WIKA profile sealings at the sealing face ①.

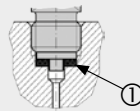

per EN 837

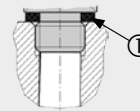

per DIN EN ISO 1179-2
(formerly DIN 3852-E)

Tapered threads

For sealing, the thread is wound with additional sealing material, e.g. PTFE tape.

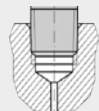

NPT, R and PT

→ For information on sealings, see WIKA data sheet AC 09.08 at www.wika.com.

Versions

Dimensions of the process connections in mm [in]



For flush process connections, see table on page 7.
The tapped holes are only shown for WIKA-specific threads. For all other tapped holes, observe the applicable standards.

Non-flush process connections

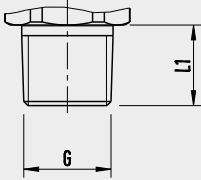
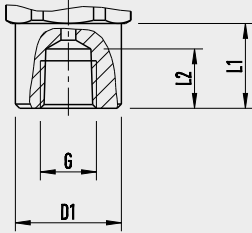
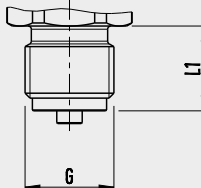
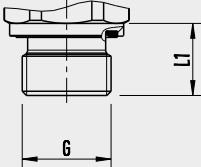
Standard	Thread	Dimensions (process connection at instrument) in mm [in]	Sketch (process connection at instrument)	
ANSI/ASME B1.20.1	1/8 NPT	G: 1/8 NPT L1: 10 [0.39]		
	1/4 NPT	G: 1/4 NPT L1: 13 [0.51]		
	1/2 NPT	G: 1/2 NPT L1: 19 [0.75]		
	1/4 NPT, female thread (for models A-10 and S-20)	G: 1/4 NPT-I D1: 25 [0.98] L1: 14 [0.55] L2: 20 [0.79]		
		1/4 NPT, female thread (for model O-10)		G: 1/4 NPT-I D1: 19 [0.75] L1: 17 [0.67] L2: 14 [0.55]
		1/4 NPT, female thread (for models C-10, E-10, F-20, N-10, P-30 and S-10)		G: 1/4 NPT-I D1: 25 [0.98] L1: 10 [0.39] L2: 14 [0.55]
DIN 16288	M12 x 1.5	G: M12 x 1.5 L1: 13 [0.51]		
	M20 x 1.5	G: M20 x 1.5 L1: 20 [0.79]		
DIN EN ISO 1179-2 (formerly DIN 3852-E)	G 1/4 A	G: G 1/4 A L1: 14 [0.55]		
	G 1/2 A	G: G 1/2 A L1: 17 [0.67]		
	M14 x 1.5	G: M14 x 1.5 L1: 14 [0.55]		

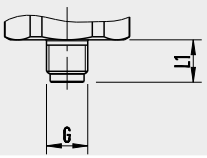
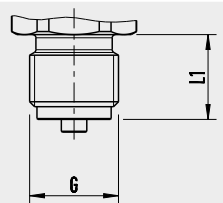
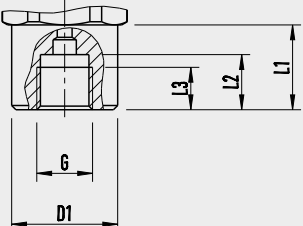
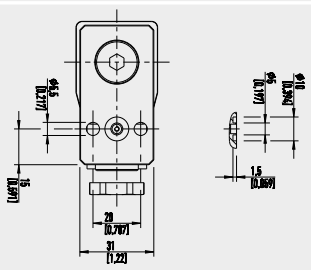
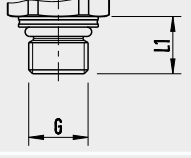
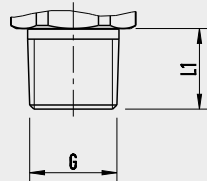
Standard	Thread	Dimensions (process connection at instrument) in mm [in]	Sketch (process connection at instrument)
EN 837	G 1/8 B	G: G 1/8 B L1: 10 [0.39]	
	G 1/4 B	G: G 1/4 B L1: 13 [0.51]	
	G 3/8 B	G: G 3/8 B L1: 16 [0.63]	
	G 1/2 B	G: G 1/2 B L1: 20 [0.79]	
	G 1/4, female thread (for models A-10, PSD-30, PSD-4 and S-20)	G: G 1/4-I D1: Ø 25 [0.98] L1: 20 [0.79] L2: 13 [0.51] L3: 10 [0.39]	
		G: G 1/4-I D1: Ø 17.5 [0.69] L1: 19.5 [0.77] L2: 13 [0.51] L3: 10 [0.39]	
		G: G 1/4-I D1: Ø 19 [0.75] L1: 17 [0.67] L2: 13 [0.51] L3: 10 [0.39]	
-	Flange connection	Diameter 5 mm	
ISO 6149-2	M14 x 1.5	G: M14 x 1.5 L1: 13.5 [0.53]	
ISO 7	R 1/4	G: R 1/4 L1: 13 [0.52]	
	R 3/8	G: R 3/8 L1: 15 [0.59]	
	R 1/2	G: R 1/2 L1: 19 [0.75]	

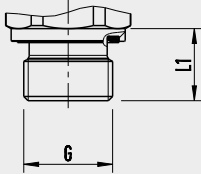
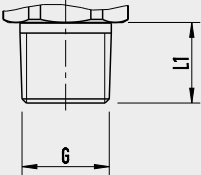
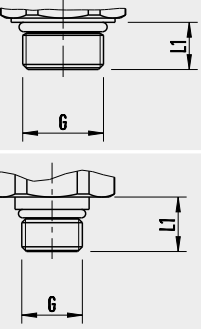
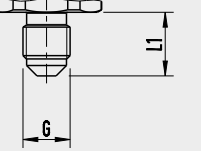
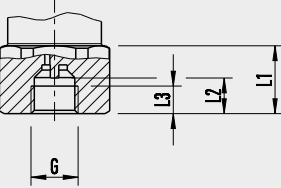
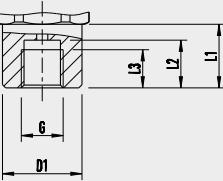
Standard	Thread	Dimensions (process connection at instrument) in mm [in]	Sketch (process connection at instrument)
JIS B2351-1	G ¼ x 10, form O with collar	G: G ¼ x 10 L1: 10 [0.39]	
	G ¾, form O with collar	G: G ¾ L1: 12 [0.47]	
KS B 0222	PT ¼	G: PT ¼ L1: 13 [0.52]	
	PT ¾	G: PT ¾ L1: 15 [0.59]	
	PT ½	G: PT ½ L1: 19 [0.75]	
SAE J514	¾-16 UNF-2A O-ring BOSS	G: ¾-16 UNF-2A L1: 11.13 [0.44]	
	7/16-20 UNF-2A O-ring BOSS	G: 7/16-20 UNF-2A L1: 12.06 [0.48]	
	9/16-18 UNF-2A O-ring BOSS	G: 9/16-20 UNF-2A L1: 12.85 [0.51]	
	7/16-20 UNF-2A 74°	G: 7/16-20 UNF-2A cone 74° L1: 15 [0.59]	
SAE J513 compatible	7/16-20 UNF-2A 90°	G: 7/16-20 UNF-2A cone 90° L1: 15 [0.59]	
SAE J515 compatible	7/16-20 UNF-2B, Schrader connection	G: 7/16-20 UNF-2B L1: 16 [0.63] L2: 8.4 [0.33] L3: 6.5 [0.26]	
Ermeto compatible	G ¼, female thread (for model PSD-4)	G: G ¼-I L1: 20 [0.79] L2: 15 [0.59] L3: 12 [0.47] D1: 25 [0.98]	
	G ¼, female thread (for model TIS-20)	G: G ¼-I L1: 20 [0.79] L2: 17.5 [0.689] L3: 14 [0.55] D1: 26.5 [1.04]	

14280340

Flush process connections

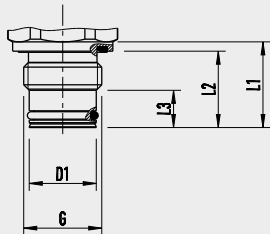
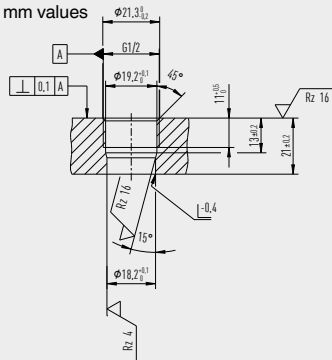
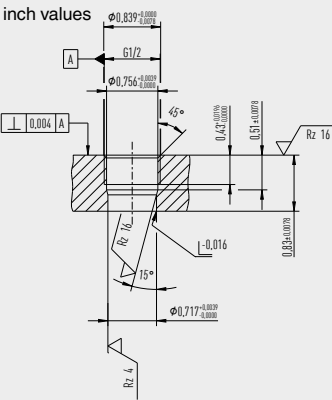
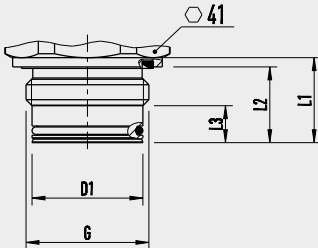
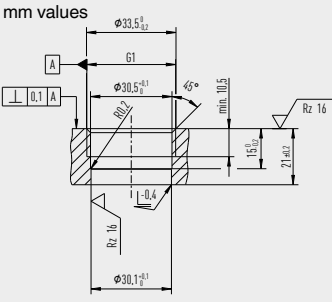
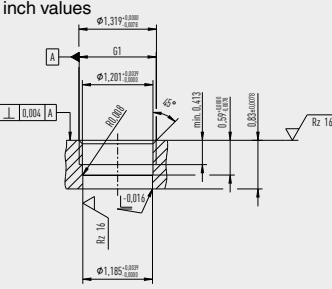
Standard	Thread	Dimensions (process connection at instrument) in mm [in]	Sketch (process connection at instrument)	Sketch (tapped hole with dimensions)
EN 837	G 1/2 B	G: G 1/2 B D1: 18 [0.71] L1: 23 [0.91] L2: 20.5 [0.807] L3: 10 [0.39]		<p>mm values</p> 
		<p>inch values</p> 		
	G 1 B	G: G 1 B D1: 30 [1.18] L1: 23 [0.91] L2: 20.5 [0.807] L3: 10 [0.39]		<p>mm values</p> 
		<p>inch values</p> 		

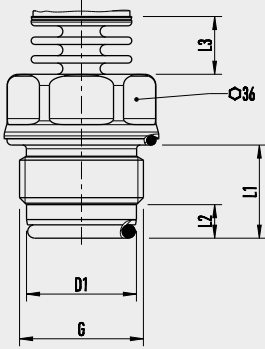
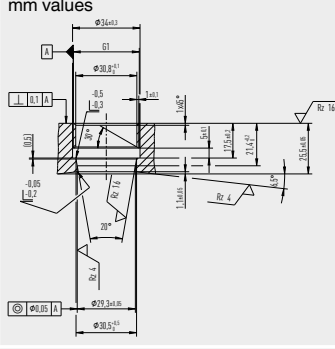
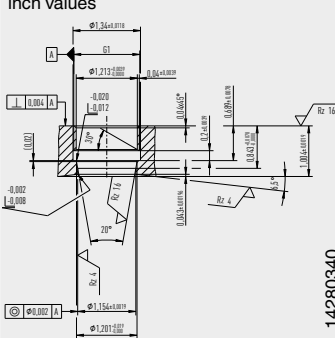
Stand-ard	Thread	Dimensions (process connection at instrument) in mm [in]	Sketch (process connection at instrument)	Sketch (tapped hole with dimensions)
EN 837	G 1 B hygienic	G: G 1 B (hygienic) D1: 29.5 [1.61] L1: 25 [0.98] L2: 9 [0.35] L3: 15.5 [0.61]		<p>mm values</p>  <p>inch values</p>  <p style="text-align: right;">14280340</p>

UHP process connections

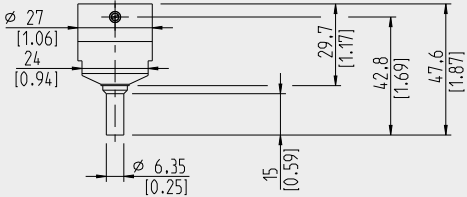
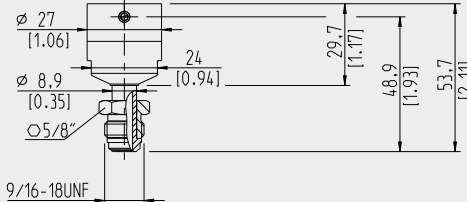
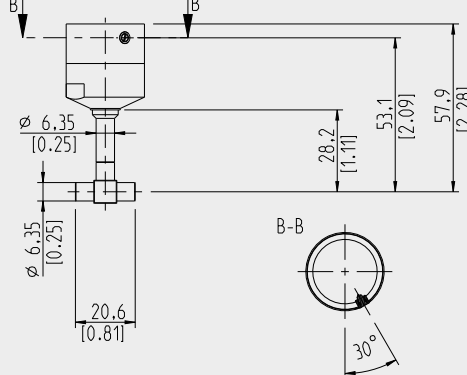
Thread	Sketch (process connection at instrument)
¼" weld stub (Max. available pressure: 300 psi)	
¼" pressure screw, rotatable VCR compatible	
¼" T-connector, weld stub	

Notes

- The sketches of the process connections shown are not to scale.
- For customer-specific versions of the pressure sensors or pressure switches, other process connections can also be used, depending on agreement. The dimensions are then part of the respective agreement and correspond to the requirements of the customer's specification.

Process connections G 1 hygienic and TRI-CLAMP®

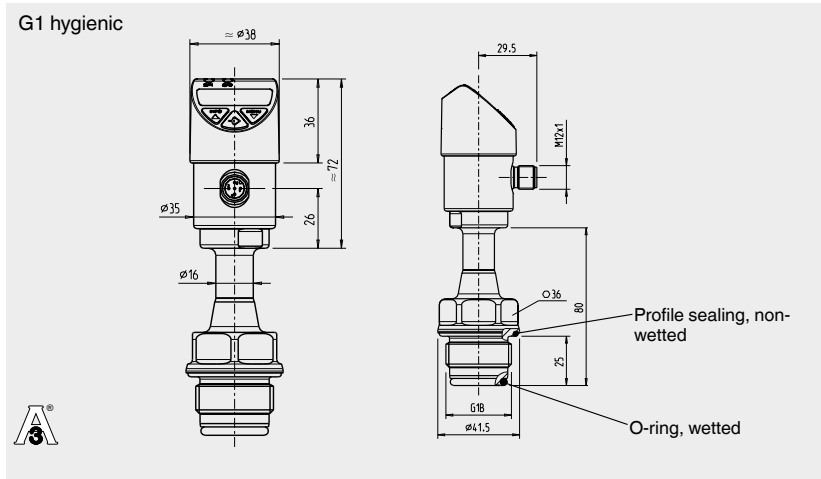

Suitable for WIKA adapter system model 910.61

For dimensions of the appropriate process adapters and welding sockets see data sheet AC 09.20

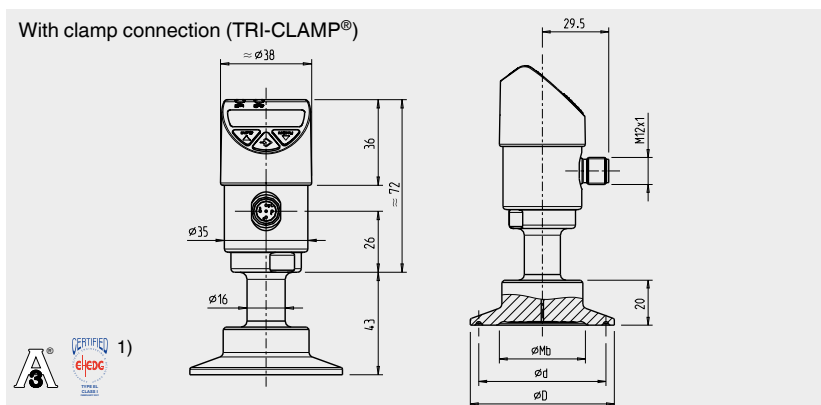

Version	Dimensions in mm		
	Ø Mb	Ø d	Ø D
Clamp connection (TRI-CLAMP®) 2) 1 ½" suitable for clamp connections per ASME BPE 1 ½", DIN 32676 row A DN 40, row C DN 1 ½", BS 4825 part 3 DN 38.1 2" suitable for clamp connections per ASME BPE 2", DIN 32676 row A DN 50, row B DN 42.4 and 48.3, row C DN 2", BS 4825 part 3 DN 50.8	32	43.5	50.5
	40	56.6	64

1) EHEDG conformity only in combination with the clamp connection with a T-ring seal from Combifit Metaalbewerking B.V.

2) For maximum pressure range consider pressure rating of clamp.

© 04/2003 WIKA Alexander Wiegand SE & Co. KG, all rights reserved.
The specifications given in this document represent the state of engineering at the time of publishing.
We reserve the right to make modifications to the specifications and materials.

07/2022 EN



WIKA Alexander Wiegand SE & Co. KG
Alexander-Wiegand-Straße 30
63911 Klingenberg/Germany
Tel. +49 9372 132-0
Fax +49 9372 132-406
info@wika.de
www.wika.de

Accessories

	Art. No.	Type No.
Straight connector, 4-pole, with PUR cable 10 m	148334	EDS-KG10
Angled connection plug, 4-pole, with PUR cable 10 m	148338	EDS-KW10