

Resistance thermometer

TR10-C type



Art. No. 148308

Type No. TR10-C.100.4.A.12.T.250



Exemplary illustration

Resistance thermometers of this series are designed for screw-fitting directly into the process, mainly in vessels and pipelines. They are suitable for liquid and gaseous media under moderate mechanical load and normal chemical conditions. The protection tube from stainless steel is fully welded and screwed into the connection head. The interchangeable measuring insert can be removed without taking out the complete sensor from the plant. This enables inspection, measuring equipment monitoring or, when servicing is necessary, replacement while the plant is running. The choice of standard lengths assists with short delivery times and the possibility of stocking spare parts.

Technical data

WIKA type	TR10-C
Housing	Aluminium
Indicating range	-30 to 300 °C
Ambient temperature	-40 to 80 °C
Cable entry	standard cable gland M20x1.5
Measuring insert Ø	6 mm
Connection to neck tube	M24x1.5 mm
Thermowell material	CrNi steel 1.4571
Connection housing	BSZ, spherical shape, hinged cover
Protection IP	IP 65
Accuracy	class A
Output signal	Pt100, 4 - 20 mA, 4-wire
Measuring range start	0 °C
Measuring range end	150 °C
Installation length	250 mm
Thread	G 1/2 ET
Transmitter	T15, digital, 4 - 20 mA, programmable

Other special versions with different insertion lengths, process connections, protection tube designs, connection heads, type and number of sensors, accuracy classes and connection methods can be individually selected for the respective application and are available on request. A large number of different explosion-protected approvals are also available for the TR10-C. Analogue or digital transmitters can optionally be mounted in the connection head of the TR10-C.

Commercial data

Customs tariff number	90251900
Country of origin	PL
eCl@ss 5.1.4	27270101
eCl@ss 9.0	27270101
UNSPSC_Code_v190501	41112200
UNSPSC_CodeDesc_v190501	Temperature sensors

Threaded resistance thermometer With protection tube Model TR10-C

WIKA data sheet TE 60.03



for further approvals
see page 2

Applications

- Machine building, plant and vessel construction
- Energy and power plant technology
- Chemical industry
- Food and beverage industry
- Sanitary, heating and air-conditioning technology

Special features

- Sensor ranges from -196 ... +600 °C [-320 ... +1.112 °F]
- With integrated fabricated protection tube
- Spring-loaded measuring insert (replaceable)
- Explosion-protected versions are available for many approval types (see page 2)

Description

Resistance thermometers of this series are designed for screw-fitting directly into the process, mainly in vessels and pipelines.

These thermometers are suitable for liquid and gaseous media under moderate mechanical load and normal chemical conditions. The protection tube from stainless steel is fully welded and screwed into the connection head. The interchangeable measuring insert can be removed without taking out the complete sensor from the plant. This enables inspection, measuring equipment monitoring or, when servicing is necessary, replacement while the plant is running. The choice of standard lengths assists with short delivery times and the possibility of stocking spare parts.



Model TR10-C with protection tube

Insertion length, process connection, protection tube design, connection head, type and number of sensors, accuracy and connection method can each be selected to suit the respective application.

A large number of different explosion-protected approvals are available for the TR10-C.

Optionally we can fit analogue or digital transmitters from the WIKA range into the connection head of the TR10-C.

WIKA data sheet TE 60.03 · 02/2021

Page 1 of 18

Data sheets showing similar products:
Threaded thermocouple; model TC10-C; see data sheet TE 65.03









Explosion protection (option)

The permissible power, P_{max} , as well as the permissible ambient temperature, for the respective category can be seen on the certificate for hazardous areas or in the operating instructions.

Transmitters have own certificates for hazardous areas. The permissible ambient temperature ranges of the built-in transmitters can be taken from the corresponding transmitter operating instructions and approvals.









Approvals (explosion protection, further approvals)

Logo	Description	Country									
 	EU declaration of conformity <ul style="list-style-type: none"> ■ EMC directive ¹⁾ EN 61326 emission (group 1, class B) and interference immunity (industrial application) ■ RoHS directive ■ ATEX directive (option) Hazardous areas <table border="0" style="width: 100%; border-collapse: collapse;"> <tr> <td style="width: 15%; vertical-align: top;">- Ex i</td> <td style="width: 35%; vertical-align: top;">Zone 0 gas Zone 1 mounting to zone 0 gas Zone 1 gas Zone 20 dust Zone 21 mounting to zone 20 dust Zone 21 dust</td> <td style="width: 50%; vertical-align: top;">II 1G Ex ia IIC T1 ... T6 Ga II 1/2G Ex ia IIC T1 ... T6 Ga/Gb II 2G Ex ia IIC T1 ... T6 Gb II 1D Ex ia IIIC T125 ... T65 °C Da II 1/2D Ex ia IIIC T125 ... T65 °C Da/Db II 2D Ex ia IIIC T125 ... T65 °C Db</td> </tr> <tr> <td style="vertical-align: top;">- Ex e ²⁾</td> <td style="vertical-align: top;">Zone 1 gas Zone 2 gas Zone 21 dust Zone 22 dust</td> <td style="vertical-align: top;">II 2G Ex eb IIC T1 ... T6 Gb ³⁾ II 3G Ex ec IIC T1 ... T6 Gc X II 2D Ex tb IIIC TX °C Db ³⁾ II 3D Ex tc IIIC TX °C Dc X</td> </tr> <tr> <td style="vertical-align: top;">- Ex n ²⁾</td> <td style="vertical-align: top;">Zone 2 gas Zone 22 dust</td> <td style="vertical-align: top;">II 3G Ex nA IIC T1 ... T6 Gc X II 3D Ex tc IIIC TX °C Dc X</td> </tr> </table>	- Ex i	Zone 0 gas Zone 1 mounting to zone 0 gas Zone 1 gas Zone 20 dust Zone 21 mounting to zone 20 dust Zone 21 dust	II 1G Ex ia IIC T1 ... T6 Ga II 1/2G Ex ia IIC T1 ... T6 Ga/Gb II 2G Ex ia IIC T1 ... T6 Gb II 1D Ex ia IIIC T125 ... T65 °C Da II 1/2D Ex ia IIIC T125 ... T65 °C Da/Db II 2D Ex ia IIIC T125 ... T65 °C Db	- Ex e ²⁾	Zone 1 gas Zone 2 gas Zone 21 dust Zone 22 dust	II 2G Ex eb IIC T1 ... T6 Gb ³⁾ II 3G Ex ec IIC T1 ... T6 Gc X II 2D Ex tb IIIC TX °C Db ³⁾ II 3D Ex tc IIIC TX °C Dc X	- Ex n ²⁾	Zone 2 gas Zone 22 dust	II 3G Ex nA IIC T1 ... T6 Gc X II 3D Ex tc IIIC TX °C Dc X	European Union
- Ex i	Zone 0 gas Zone 1 mounting to zone 0 gas Zone 1 gas Zone 20 dust Zone 21 mounting to zone 20 dust Zone 21 dust	II 1G Ex ia IIC T1 ... T6 Ga II 1/2G Ex ia IIC T1 ... T6 Ga/Gb II 2G Ex ia IIC T1 ... T6 Gb II 1D Ex ia IIIC T125 ... T65 °C Da II 1/2D Ex ia IIIC T125 ... T65 °C Da/Db II 2D Ex ia IIIC T125 ... T65 °C Db									
- Ex e ²⁾	Zone 1 gas Zone 2 gas Zone 21 dust Zone 22 dust	II 2G Ex eb IIC T1 ... T6 Gb ³⁾ II 3G Ex ec IIC T1 ... T6 Gc X II 2D Ex tb IIIC TX °C Db ³⁾ II 3D Ex tc IIIC TX °C Dc X									
- Ex n ²⁾	Zone 2 gas Zone 22 dust	II 3G Ex nA IIC T1 ... T6 Gc X II 3D Ex tc IIIC TX °C Dc X									
 	IECEx (option) - in conjunction with ATEX Hazardous areas <table border="0" style="width: 100%; border-collapse: collapse;"> <tr> <td style="width: 15%; vertical-align: top;">- Ex i</td> <td style="width: 35%; vertical-align: top;">Zone 0 gas Zone 1 mounting to zone 0 gas Zone 1 gas Zone 20 dust Zone 21 mounting to zone 20 dust Zone 21 dust</td> <td style="width: 50%; vertical-align: top;">Ex ia IIC T1 ... T6 Ga Ex ia IIC T1 ... T6 Ga/Gb Ex ia IIC T1 ... T6 Gb Ex ia IIIC T125 ... T65 °C Da Ex ia IIIC T125 ... T65 °C Da/Db Ex ia IIIC T125 ... T65 °C Db</td> </tr> </table>	- Ex i	Zone 0 gas Zone 1 mounting to zone 0 gas Zone 1 gas Zone 20 dust Zone 21 mounting to zone 20 dust Zone 21 dust	Ex ia IIC T1 ... T6 Ga Ex ia IIC T1 ... T6 Ga/Gb Ex ia IIC T1 ... T6 Gb Ex ia IIIC T125 ... T65 °C Da Ex ia IIIC T125 ... T65 °C Da/Db Ex ia IIIC T125 ... T65 °C Db	International						
- Ex i	Zone 0 gas Zone 1 mounting to zone 0 gas Zone 1 gas Zone 20 dust Zone 21 mounting to zone 20 dust Zone 21 dust	Ex ia IIC T1 ... T6 Ga Ex ia IIC T1 ... T6 Ga/Gb Ex ia IIC T1 ... T6 Gb Ex ia IIIC T125 ... T65 °C Da Ex ia IIIC T125 ... T65 °C Da/Db Ex ia IIIC T125 ... T65 °C Db									
	EAC (option) Hazardous areas <table border="0" style="width: 100%; border-collapse: collapse;"> <tr> <td style="width: 15%; vertical-align: top;">- Ex i</td> <td style="width: 35%; vertical-align: top;">Zone 0 gas Zone 1 gas Zone 20 dust Zone 21 dust</td> <td style="width: 50%; vertical-align: top;">0Ex ia IIC T6 ... T1 Ga X 1Ex ia IIC T6 ... T1 Gb X Ex ia IIIC T80...T440 °C Da X Ex ia IIIC T80...T440 °C Db X</td> </tr> <tr> <td style="vertical-align: top;">- Ex n</td> <td style="vertical-align: top;">Zone 2 gas</td> <td style="vertical-align: top;">2Ex nA IIC T6 ... T1 Gc X</td> </tr> </table>	- Ex i	Zone 0 gas Zone 1 gas Zone 20 dust Zone 21 dust	0Ex ia IIC T6 ... T1 Ga X 1Ex ia IIC T6 ... T1 Gb X Ex ia IIIC T80...T440 °C Da X Ex ia IIIC T80...T440 °C Db X	- Ex n	Zone 2 gas	2Ex nA IIC T6 ... T1 Gc X	Eurasian Economic Community			
- Ex i	Zone 0 gas Zone 1 gas Zone 20 dust Zone 21 dust	0Ex ia IIC T6 ... T1 Ga X 1Ex ia IIC T6 ... T1 Gb X Ex ia IIIC T80...T440 °C Da X Ex ia IIIC T80...T440 °C Db X									
- Ex n	Zone 2 gas	2Ex nA IIC T6 ... T1 Gc X									
	Ex Ukraine (option) Hazardous areas <table border="0" style="width: 100%; border-collapse: collapse;"> <tr> <td style="width: 15%; vertical-align: top;">- Ex i</td> <td style="width: 35%; vertical-align: top;">Zone 0 gas Zone 1 mounting to zone 0 gas Zone 1 gas Zone 20 dust Zone 21 mounting to zone 20 dust Zone 21 dust</td> <td style="width: 50%; vertical-align: top;">II 1G Ex ia IIC T1 ... T6 Ga II 1/2G Ex ia IIC T1 ... T6 Ga/Gb II 2G Ex ia IIC T1 ... T6 Gb II 1D Ex ia IIIC T65°C Da II 1/2D Ex ia IIIC T65°C Da/Db II 2D Ex ia IIIC T65°C Db</td> </tr> </table>	- Ex i	Zone 0 gas Zone 1 mounting to zone 0 gas Zone 1 gas Zone 20 dust Zone 21 mounting to zone 20 dust Zone 21 dust	II 1G Ex ia IIC T1 ... T6 Ga II 1/2G Ex ia IIC T1 ... T6 Ga/Gb II 2G Ex ia IIC T1 ... T6 Gb II 1D Ex ia IIIC T65°C Da II 1/2D Ex ia IIIC T65°C Da/Db II 2D Ex ia IIIC T65°C Db	Ukraine						
- Ex i	Zone 0 gas Zone 1 mounting to zone 0 gas Zone 1 gas Zone 20 dust Zone 21 mounting to zone 20 dust Zone 21 dust	II 1G Ex ia IIC T1 ... T6 Ga II 1/2G Ex ia IIC T1 ... T6 Ga/Gb II 2G Ex ia IIC T1 ... T6 Gb II 1D Ex ia IIIC T65°C Da II 1/2D Ex ia IIIC T65°C Da/Db II 2D Ex ia IIIC T65°C Db									



1) Only for built-in transmitter

2) Only for connection head model BSZ or BSZ-H (see "Connection head")

3) Without transmitter

Logo	Description	Country
	INMETRO (option) Hazardous areas - Ex i Zone 0 gas Ex ia IIC T3 ... T6 Ga Zone 1 mounting to zone 0 gas Ex ia IIC T3 ... T6 Ga/Gb Zone 20 dust Ex ia IIIC T125 ... T65 °C Da Zone 21 mounting to zone 20 dust Ex ia IIIC T125 ... T65 °C Da/Db	Brazil
	CCC (option) Hazardous areas - Ex i Zone 0 gas Ex ia IIC T1 ~ T6 Ga Zone 1 gas Ex ia IIC T1 ~ T6 Gb Zone 1 mounting to zone 0 gas Ex ia IIC T1 ~ T6 Ga/Gb Zone 2 gas Ex ic IIC T1 ~ T6 Gc Zone 20 dust Ex iaD 20 T65/T95/T125°C Zone 21 dust Ex iaD 21 T65/T95/T125°C Zone 21 mounting to zone 20 dust Ex iaD 20/21 T65/T95/T125°C - Ex n Zone 2 gas Ex nA IIC T1 ~ T6 Gc	China
	KCs - KOSHA (option) Hazardous areas - Ex i Zone 0 gas Ex ia IIC T4 ... T6 Zone 1 gas Ex ib IIC T4 ... T6	South Korea
-	PESO (option) Hazardous areas - Ex i Zone 0 gas Ex ia IIC T1 ... T6 Ga Zone 1 mounting to zone 0 gas Ex ia IIC T1 ... T6 Ga/Gb Zone 1 gas Ex ia IIC T1 ... T6 Gb	India
	GOST (option) Metrology, measurement technology	Russia
	KazInMetr (option) Metrology, measurement technology	Kazakhstan
-	MTSCHS (option) Permission for commissioning	Kazakhstan
	BelGIM (option) Metrology, measurement technology	Belarus
	UkrSEPRO (option) Metrology, measurement technology	Ukraine
	Uzstandard (option) Metrology, measurement technology	Uzbekistan

Manufacturer's information and certifications

Logo	Description
	SIL 2 Functional safety (only in conjunction with model T32 temperature transmitter)
	NAMUR NE 024 Hazardous areas (Ex i)

Instruments marked with "ia" may also be used in areas only requiring instruments marked with "ib" or "ic".
If an instrument with "ia" marking has been used in an area with requirements in accordance with "ib" or "ic", it can no longer be operated in areas with requirements in accordance with "ia" afterwards.

Approvals and certificates, see website

Sensor

Measuring element

Pt100, Pt1000 ¹⁾ (measuring current: 0.1 ... 1.0 mA) ²⁾

Connection method	
Single elements	1 x 2-wire 1 x 3-wire 1 x 4-wire
Dual elements	2 x 2-wire 2 x 3-wire 2 x 4-wire ³⁾

Validity limits of class accuracy per EN 60751		
Class	Sensor construction	
	Wire-wound	Thin-film
Class B	-196 ... +600 °C	-50 ... +500 °C
	-196 ... +450 °C	-50 ... +250 °C
Class A ⁴⁾	-100 ... +450 °C	-30 ... +300 °C
Class AA ⁴⁾	-50 ... +250 °C	0 ... 150 °C

- 1) Pt1000 only available as a thin-film measuring resistor
 2) For detailed specifications for Pt100 sensors, see Technical information IN 00.17 at www.wika.com.
 3) Not with 3 mm diameter
 4) Not with 2-wire connection method

The table shows the temperature ranges listed in the respective standards, in which the tolerance values (class accuracies) are valid.

Electrical connection (colour code per IEC/EN 60751)

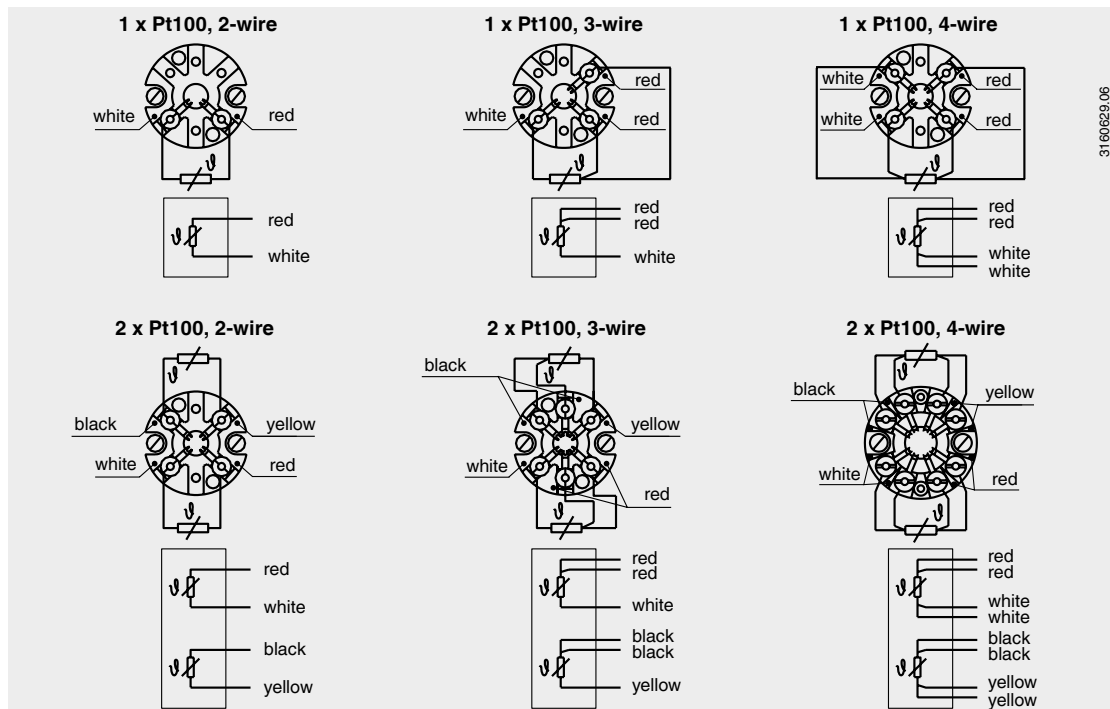

For the electrical connections of built-in temperature transmitters see the corresponding data sheets or operating instructions.

Connection head

■ European designs per EN 50446 / DIN 43735

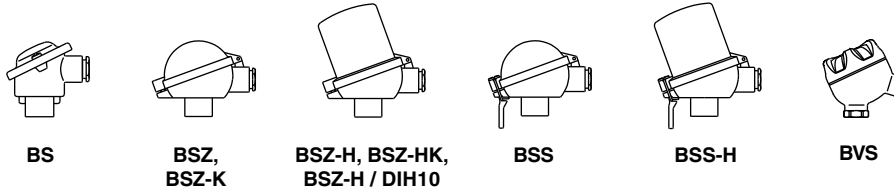

Model	Material	Cable entry thread size	Ingress protection (max) ¹⁾ IEC/EN 60529	Cap	Surface	Connection to neck tube
BS	Aluminium	M20 x 1.5 or ½ NPT ³⁾	IP65 ⁴⁾	Flat cap with 2 screws	Blue, painted ⁵⁾	M24 x 1.5, ½ NPT
BSZ	Aluminium	M20 x 1.5 or ½ NPT ³⁾	IP65 ⁴⁾	Spherical hinged cover with cylinder head screw	Blue, painted ⁵⁾	M24 x 1.5, ½ NPT
BSZ-H	Aluminium	M20 x 1.5 or ½ NPT ³⁾	IP65 ⁴⁾	Raised hinged cover with cylinder head screw	Blue, painted ⁵⁾	M24 x 1.5, ½ NPT
BSZ-H (2x cable outlet)	Aluminium	2 x M20 x 1.5 or 2 x ½ NPT ³⁾	IP65 ⁴⁾	Raised hinged cover with cylinder head screw	Blue, painted ⁵⁾	M24 x 1.5
BSZ-H / DIH10²⁾	Aluminium	M20 x 1.5 or ½ NPT ³⁾	IP65	Raised hinged cover with cylinder head screw	Blue, painted ⁵⁾	M24 x 1.5, ½ NPT
BSS	Aluminium	M20 x 1.5 or ½ NPT ³⁾	IP65	Spherical hinged cover with clamping lever	Blue, painted ⁵⁾	M24 x 1.5, ½ NPT
BSS-H	Aluminium	M20 x 1.5 or ½ NPT ³⁾	IP65	Raised hinged cover with clamping lever	Blue, painted ⁵⁾	M24 x 1.5, ½ NPT
BVS	Stainless steel	M20 x 1.5 ³⁾	IP65	Precision-cast screw-on lid	Blank, electropolished	M24 x 1.5
BSZ-K	Plastic	M20 x 1.5 or ½ NPT ³⁾	IP65	Spherical hinged cover with cylinder head screw	Black	M24 x 1.5
BSZ-HK	Plastic	M20 x 1.5 or ½ NPT ³⁾	IP65	Raised hinged cover with cylinder head screw	Black	M24 x 1.5

Model	Explosion protection					
	without	Ex i (gas) Zone 0, 1, 2	Ex i (dust) Zone 20, 21, 22	Ex e (gas) Zone 1, 2	Ex t (dust) Zone 21, 22	Ex nA (gas) Zone 2
BS	x	x	x	-	-	-
BSZ	x	x	x	x ⁶⁾	x ⁶⁾	x ⁷⁾
BSZ-H	x	x	x	x ⁶⁾	x ⁶⁾	x ⁷⁾
BSZ-H (2x cable outlet)	x	x	x	x ⁶⁾	x ⁶⁾	x ⁷⁾
BSZ-H / DIH10¹⁾	x	x	-	-	-	-
BSS	x	x	-	-	-	-
BSS-H	x	x	-	-	-	-
BVS	x	x	-	-	-	-
BSZ-K	x	x	-	-	-	-
BSZ-HK	x	x	-	-	-	-

1) IP ingress protection of the connection head. The IP ingress protections of the complete instrument TR10-C must not inevitably correspond to the connection head.

2) LED display DIH10

3) Standard (others on request)

4) Ingress protections, which describe temporary or lasting submersion, available on request

5) RAL 5022

6) Only ATEX and CCC

7) Only ATEX, CCC and EAC-Ex

■ North American designs



KN4-A
KN4-P

Model	Material	Cable entry thread size	Ingress protection (max.) ¹⁾ IEC/EN 60529	Cover / Cap	Surface	Connection to neck tube
KN4-A	Aluminium	½ NPT or M20 x 1.5 ²⁾	IP65	Screw-on lid	Blue, painted ³⁾	M24 x 1.5, ½ NPT
KN4-P ⁴⁾	Polypropylene	½ NPT	IP65	Screw-on lid	White	½ NPT

Model	Explosion protection					
	without	Ex i (gas) Zone 0, 1, 2	Ex i (dust) Zone 20, 21, 22	Ex e (gas) Zone 1, 2	Ex t (dust) Zone 21, 22	Ex nA (gas) Zone 2
KN4-A	x	x	-	-	-	-
KN4-P ⁴⁾	x	-	-	-	-	-

1) IP ingress protection of the connection head. The IP ingress protections of the complete instrument TR10-C must not inevitably correspond to the connection head.

2) Standard (others on request)

3) RAL 5022

4) On request

Connection head with digital display



Connection head BSZ-H with LED display model DIH10

see data sheet AC 80.11

To operate the digital displays, a transmitter with a 4 ... 20 mA output is always required.

Cable entry



The pictures show examples of connection heads.

Cable entry	Cable entry thread size	Min./max. ambient temperature
Standard cable entry ¹⁾	M20 x 1.5 or ½ NPT	-40 ... +80 °C
Plastic cable gland (cable Ø 6 ... 10 mm) ¹⁾	M20 x 1.5 or ½ NPT	-40 ... +80 °C
Plastic cable gland (cable Ø 6 ... 10 mm), Ex e ¹⁾	M20 x 1.5 or ½ NPT	-20 ... +80 °C (standard) -40 ... +70 °C (option)
Nickel-plated brass cable gland (cable Ø 6 ... 12 mm)	M20 x 1.5 or ½ NPT	-40 ... +80 °C
Stainless steel cable gland (cable Ø 7 ... 12 mm)	M20 x 1.5 or ½ NPT	-40 ... +80 °C
Plain threaded	M20 x 1.5 or ½ NPT	-
2 x M20 x 1.5 ²⁾	2 x M20 x 1.5	-
Junction box M12 x 1 (4-pin) ³⁾	M20 x 1.5	-40 ... +80 °C
Sealing plugs for transport	M20 x 1.5 or ½ NPT	-40 ... +80 °C

Cable entry	Colour	Ingress protection (max.) ⁴⁾ IEC/EN 60529	Explosion protection					
			without	Ex i (gas) Zone 0, 1, 2	Ex i (dust) Zone 20, 21, 22	Ex e (gas) Zone 1, 2	Ex t (dust) Zone 21, 22	Ex nA (gas) Zone 2
Standard cable entry ¹⁾	Blank	IP65	x	x	-	-	-	-
Plastic cable gland ¹⁾	Black or grey	IP66 ⁵⁾	x	x	-	-	-	-
Plastic cable gland, Ex e ¹⁾	Light blue	IP66 ⁵⁾	x	x	x	-	-	-
Plastic cable gland, Ex e ¹⁾	Black	IP66 ⁵⁾	x	x	x	x	x	x
Nickel-plated brass cable gland	Blank	IP66 ⁵⁾	x	x	x	-	-	-
Nickel-plated brass cable gland, Ex e	Blank	IP66 ⁵⁾	x	x	x	x	x	x
Stainless steel cable gland	Blank	IP66 ⁵⁾	x	x	x	-	-	-
Stainless steel cable gland, Ex e	Blank	IP66 ⁵⁾	x	x	x	x	x	x
Plain threaded	-	IP00	x	x	x ⁷⁾	x ⁷⁾	x ⁷⁾	x ⁷⁾
2 x M20 x 1.5 ²⁾	-	IP00	x	x	x ⁷⁾	x ⁷⁾	x ⁷⁾	x ⁷⁾
Junction box M12 x 1 (4-pin) ³⁾	-	IP65	x	x ⁶⁾	x ⁶⁾	-	-	-
Sealing plugs for transport	Transparent	-	not applicable, transport protection					

1) Not available for BVS connection head

2) Only for BSZ-H connection head

3) Not available for ½ NPT thread size cable entry

4) IP ingress protection of the cable gland. The IP ingress protections of the complete instrument TR10-C must not inevitably correspond to the cable gland.

5) Ingress protections, which describe temporary or continuous immersion, available on request

6) With appropriate mating connector connected

7) Suitable cable gland required for operation

Ingress protection per IEC/EN 60529

Degrees of protection against solid foreign bodies (defined by the first index number)

First index number	Degree of protection / short description	Test parameter
5	Dust-protected	per IEC/EN 60529
6	Dust-tight	per IEC/EN 60529

Degrees of protection against water (defined by the second index number)

Second index number	Degree of protection / short description	Test parameter
4	Protected against splash water	per IEC/EN 60529
5	Protected against water jets	per IEC/EN 60529
6	Protected against strong water jets	per IEC/EN 60529
7 ¹⁾	Protected against the effects of temporary immersion in water	per IEC/EN 60529
8 ¹⁾	Protected against the effects of continuous immersion in water	by agreement

1) Ingress protections, describing temporary or permanent immersion, on request

Standard ingress protection of model TR10-C is IP65.

The stated degrees of protection apply under the following conditions:

- Use of a suitable cable gland
- Use of a cable cross-section appropriate for the gland or select the appropriate cable gland for the available cable
- Adhere to the tightening torques for all threaded connections

Transmitter

Mounting onto the measuring insert

With mounting on the measuring insert, the transmitter replaces the terminal block and is fixed directly to the terminal plate of the measuring insert.

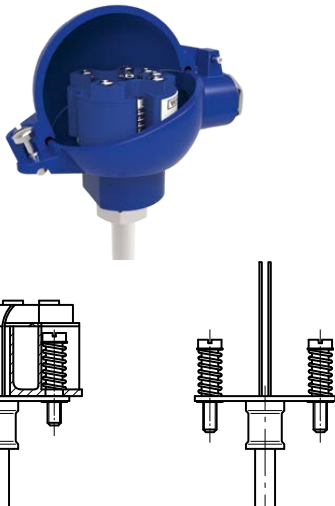

Fig. left: Measuring insert with mounted transmitter (here: model T32)
Fig. right: Measuring insert prepared for transmitter mounting

Mounted within the cap of the connection head

Mounting the transmitter in the cap of the connection head is preferable to mounting it on the measuring insert. With this type of mounting, for one, a better thermal insulation is ensured, and in addition, exchange and mounting for servicing is simplified.



Transmitter models

Output signal 4 ... 20 mA, HART® protocol		
Transmitter (selectable versions)	Model T15	Model T32
Data sheet	TE 15.01	TE 32.04
Output		
4 ... 20 mA	x	x
HART® protocol	-	x
Connection method		
1 x 2-wire, 3-wire or 4-wire	x	x
Measuring current	< 0.2 mA	< 0.3 mA
Explosion protection	Optional	Optional

Possible mounting positions for transmitters

Connection head	T15	T32
BS	○	-
BSZ, BSZ-K	○	○
BSZ-H, BSZ-HK	●	●
BSZ-H (2x cable outlet)	●	●
BSZ-H / DIH10	○	○
BSS	○	○
BSS-H	●	●
BVS	○	○
KN4-A / KN4-P	○	○

○ Mounted instead of terminal block ● Mounted within the cap of the connection head – Mounting not possible

The mounting of a transmitter on the measuring insert is possible with all the connection heads listed here. The fitting of a transmitter in the (screw) cap of a North American design connection head is not possible.

Mounting of 2 transmitters on request.

For a correct determination of the overall measuring deviation, the sensor and transmitter measuring deviations must be added.

**Functional safety (option)
with temperature transmitter model T32**

In safety-critical applications, the entire measuring chain must be taken into consideration in terms of the safety parameters. The SIL classification allows the assessment of the risk reduction reached by the safety installations.

Selected TR10-C resistance thermometers, in combination with a suitable temperature transmitter (e.g. model T32.1S, TÜV certified SIL version for protection systems developed

in accordance with IEC 61508), are suitable as sensors for safety functions to SIL 2.

For detailed specifications, see Technical information IN 00.19 at www.wika.com.

Components model TR10-C

Process connection: mounting thread, firmly welded

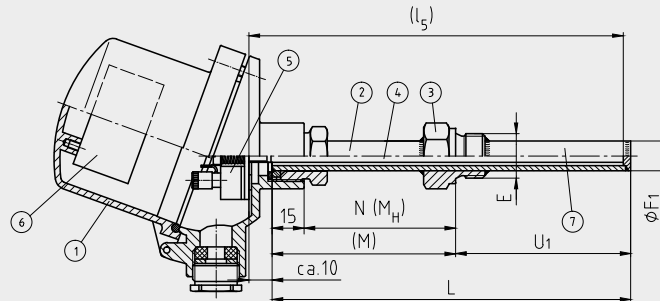

3175431.07

Process connection: compression fitting

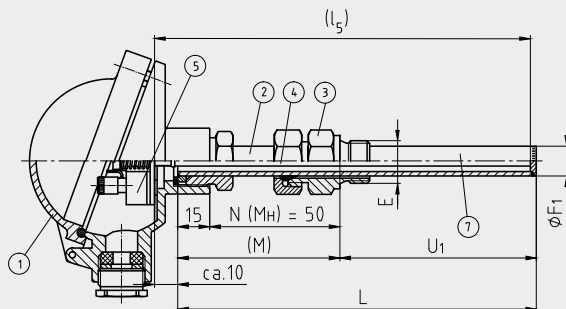

Legend:

- | | |
|---------------------------------------|--|
| ① Connection head | (L) Overall length protection tube |
| ② Neck tube | l_5 Measuring insert length |
| ③ Process connection | U_1 Protection tube insertion length per DIN 43772 |
| ④ Measuring insert (TR10-A) | $\varnothing F_1$ Protection tube diameter |
| ⑤ Terminal block/transmitter (option) | E Mounting thread |
| ⑥ Transmitter (option) | N (M _H) Neck length |
| ⑦ Protection tube | (M) Neck tube length |

Fig. with parallel or tapered thread see chapter "Protection tube"

Protection tube

Protection tube designs

Protection tube straight, mounting thread, form 2G DIN 43772

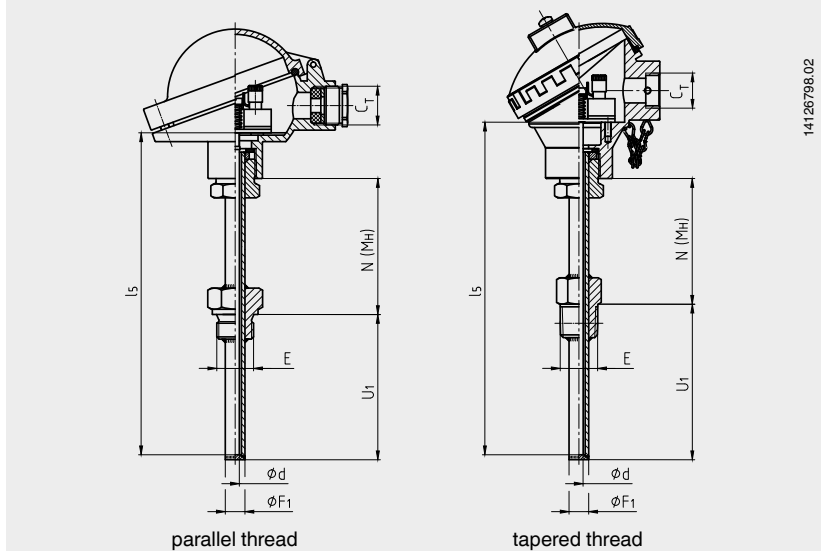

Protection tube straight, plain, form 2 DIN 43772, with/without compression fitting

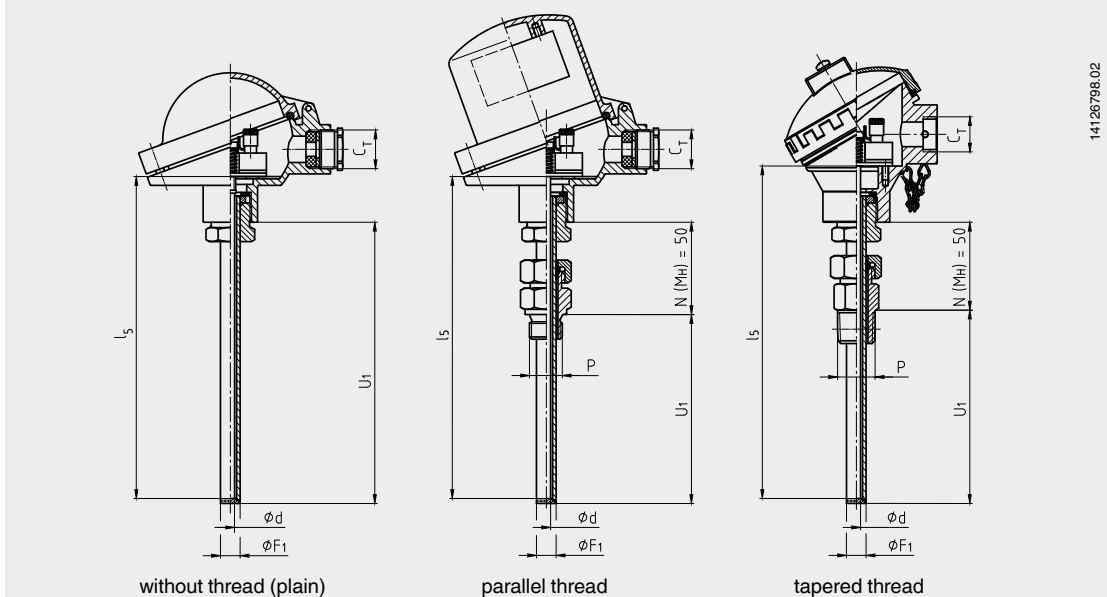

Legend:

U_1	Insertion length	ϕF_1	Protection tube diameter
l_5	Measuring insert length	E	Mounting thread
$N (M_H)$	Neck length	ϕd	Measuring insert diameter
C_T	Thread cable entry	P	Compression fitting mounting thread

The pictures show examples of connection heads.

Protection tube tapered, mounting thread, form 3G DIN 43772

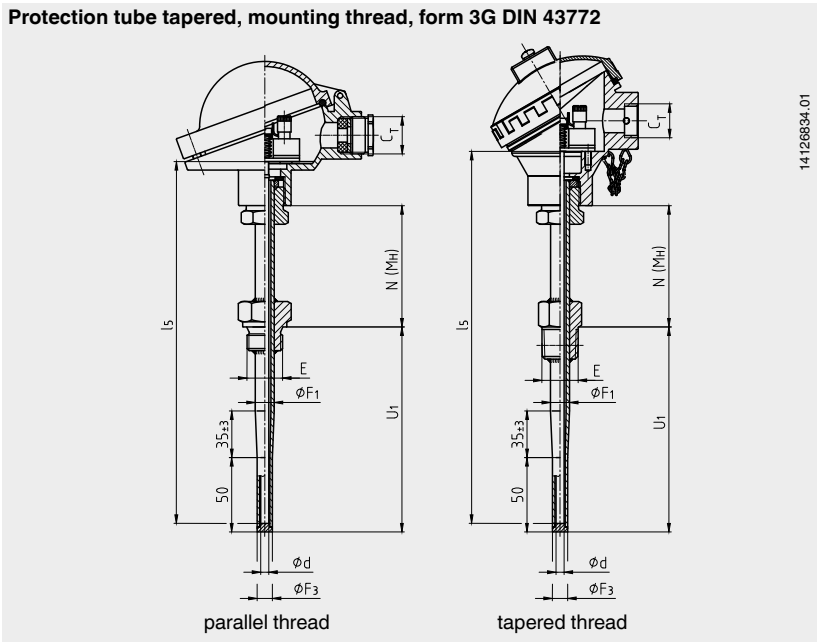

Protection tube tapered, plain, form 3 DIN 43772, with/without compression fitting

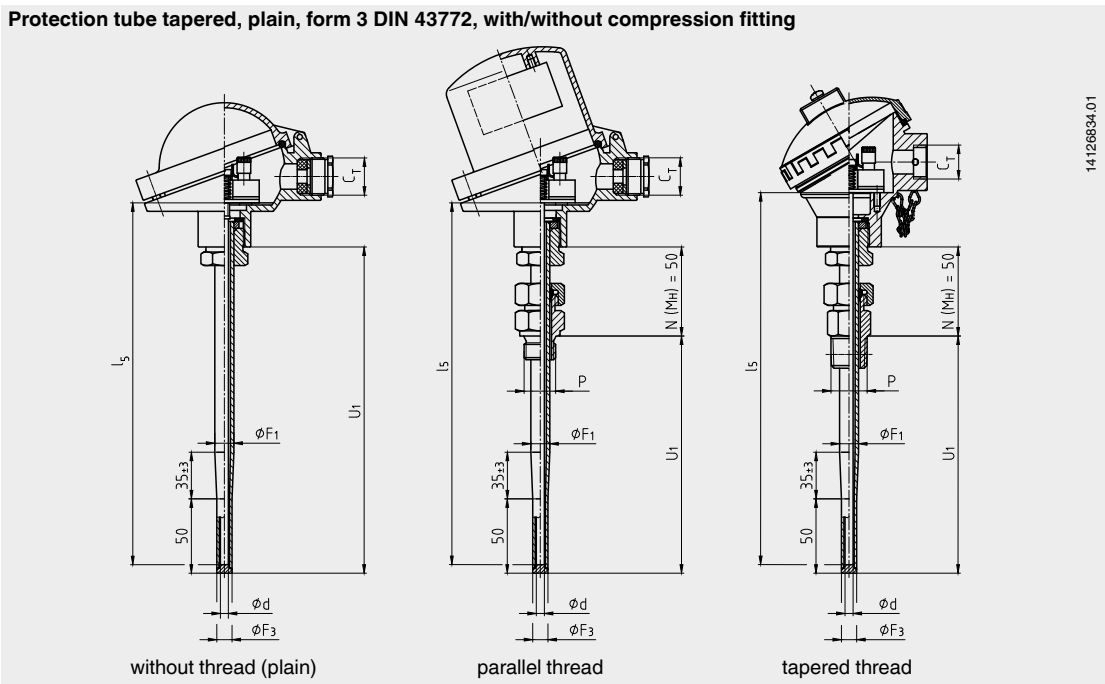

Legend:

U ₁	Insertion length	Ø F ₃	Diameter of protection tube tip
l _s	Measuring insert length	E	Mounting thread
N (M _H)	Neck length	Ø d	Measuring insert diameter
C _T	Thread cable entry	P	Compression fitting mounting thread
Ø F ₁	Protection tube diameter		

The pictures show examples of connection heads.

Protection tube tapered, weld-on solid tip, mounting thread, non-standard design

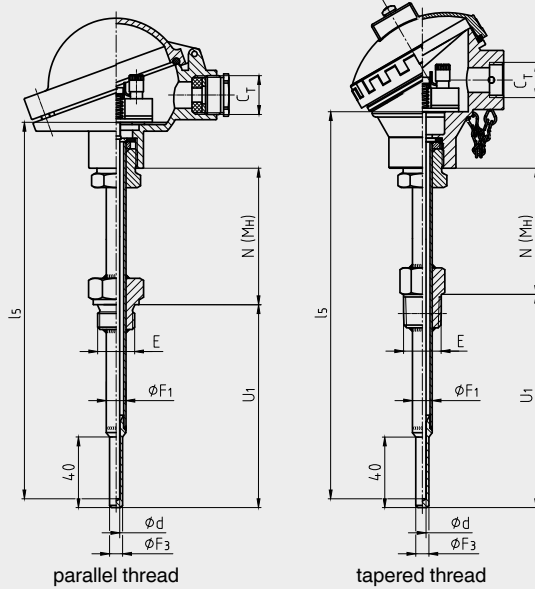

Protection tube tapered, weld-on solid tip, plain, with/without compression fitting

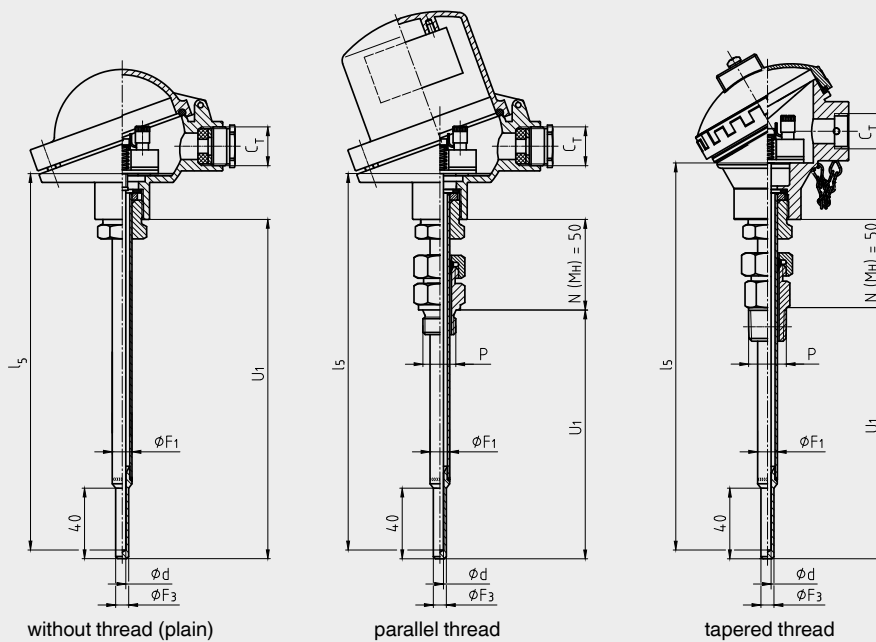

Legend:

U ₁	Insertion length	Ø F ₁	Protection tube diameter
l ₅	Measuring insert length	Ø F ₃	Diameter of protection tube tip
N (M _H)	Neck length	E	Mounting thread
K _E	1/2 NPT: 8.13 mm	Ø d	Measuring insert diameter
	3/4 NPT: 8.61 mm	P	Compression fitting mounting thread
C _T	Thread cable entry		

The pictures show examples of connection heads.

Protection tube designs

The protection tubes are made of drawn tube with a welded bottom and are screwed into the connection head with a rotatable threaded connection (male nut). By loosening this male nut, the connection head - and thus the cable outlet - can be adjusted to the desired position. The process connection is welded on to customer specification at the factory. This determines the insertion length. Insertion lengths to DIN standards are preferable.

The immersion depth into the process medium should be at least 10 times the protection tube outer diameter.

For replacement requirements use model TW35 protection tube.

Protection tube per DIN 43772	Protection tube diameter	Process connection	Suitable for measuring insert diameter	Connection to head	Material
Straight, form 2G, mounting thread	9 x 1 mm	G 1/4 B, mounting thread	6 mm	M24 x 1.5 (rotatable threaded connection, male nut)	1.4571
		G 1/2 B, mounting thread			
		G 3/4 B, mounting thread			
		G 1 B, mounting thread			
		M18 x 1.5, mounting thread			
		M20 x 1.5, mounting thread			
		M27 x 2, mounting thread			
		1/2 NPT, mounting thread			
		3/4 NPT, mounting thread			
	11 x 2 mm 12 x 2.5 mm	G 1/2 B, mounting thread	6 mm		
		G 3/4 B, mounting thread			
		G 1 B, mounting thread			
		M18 x 1.5, mounting thread			
		M20 x 1.5, mounting thread			
		M27 x 2, mounting thread			
		1/2 NPT, mounting thread			
		3/4 NPT, mounting thread			
		14 x 2.5 mm			
	G 3/4 B, mounting thread				
	G 1 B, mounting thread				
	M18 x 1.5, mounting thread				
M20 x 1.5, mounting thread					
M27 x 2, mounting thread					
1/2 NPT, mounting thread					
3/4 NPT, mounting thread					
Tapered, form 3G, mounting thread	12 x 2.5 mm, tapered to 9 mm		G 1/2 B, mounting thread	6 mm	
		G 3/4 B, mounting thread			
		G 1 B, mounting thread			
		M18 x 1.5, mounting thread			
		M20 x 1.5, mounting thread			
		M27 x 2, mounting thread			
		1/2 NPT, mounting thread			
		3/4 NPT, mounting thread			
		Straight, plain, form 2, with/without compression fitting	9 x 1 mm 11 x 2 mm 12 x 2.5 mm		G 1/2 B compression fitting (metal ferrule)
1/2 NPT compression fitting (metal ferrule)					
Without threaded connection, plain					
Tapered, plain, form 3, with/without compression fitting	12 x 2.5 mm, tapered to 9 mm	G 1/2 B compression fitting (metal ferrule)	6 mm		
		1/2 NPT compression fitting (metal ferrule)			
		Without threaded connection, plain			

other versions on next page

Tapered protection tube, non-standard	Protection tube diameter	Process connection	Suitable for measuring insert diameter	Connection to head	Material
Tapered, weld-on solid tip, mounting thread	9 x 1 mm, tapered to 6 mm	G 1/4 B, mounting thread	3 mm	M24 x 1.5 (rotatable threaded connection, male nut)	1.4571
		G 1/2 B, mounting thread			
		G 3/4 B, mounting thread			
		G 1 B, mounting thread			
		M18 x 1.5, mounting thread			
		M20 x 1.5, mounting thread			
		M27 x 2, mounting thread			
		1/2 NPT, mounting thread			
		3/4 NPT, mounting thread			
		11 x 2 mm, tapered to 6 mm 12 x 2.5 mm, tapered to 6 mm			
	G 3/4 B, mounting thread				
	G 1 B, mounting thread				
	M14 x 1.5, mounting thread				
	9 x 1 mm, tapered to 6 mm 11 x 2 mm, tapered to 6 mm 12 x 2.5 mm, tapered to 6 mm	M18 x 1.5, mounting thread			
M20 x 1.5, mounting thread					
1/2 NPT, mounting thread					
3/4 NPT, mounting thread					
Without threaded connection, plain					

Straight protection tube, non-standard	Protection tube diameter	Process connection	Suitable for measuring insert diameter	Connection to head	Material
Straight, mounting thread	6 x 1 mm 8 x 1 mm	G 1/4 B, mounting thread	3 mm	M24 x 1.5 (rotatable threaded connection, male nut)	1.4571 316L (8 x 1 mm)
		G 1/2 B, mounting thread			
		M18 x 1.5, mounting thread			
		M20 x 1.5, mounting thread			
		1/2 NPT, mounting thread			
	10 x 1 mm 10 x 1.5 mm	G 1/2 B, mounting thread	6 mm		316L
		G 3/4 B, mounting thread			
		G 1 B, mounting thread			
		M18 x 1.5, mounting thread			
		M20 x 1.5, mounting thread			
		M27 x 2, mounting thread			
		1/2 NPT, mounting thread			
	12 x 1 mm 12 x 1.5 mm	3/4 NPT, mounting thread	8 mm (6 mm with sleeve)		316L
		G 1/2 B, mounting thread			
		G 3/4 B, mounting thread			
		G 1 B, mounting thread			
		M18 x 1.5, mounting thread			
		M20 x 1.5, mounting thread			
M27 x 2, mounting thread					
1/2 NPT, mounting thread					
3/4 NPT, mounting thread					

other versions on next page

Straight protection tube, non-standard	Protection tube diameter	Process connection	Suitable for measuring insert diameter	Connection to head	Material
Straight, plain, with/without compression fitting	6 x 1 mm 8 x 1 mm	G 1/2 B compression fitting (metal ferrule)	3 mm	M24 x 1.5 (rotatable threaded connection, male nut)	1.4571 316L (8 x 1 mm)
		1/2 NPT compression fitting (metal ferrule)			
		Without threaded connection, plain			
	9 x 1 mm 10 x 1 mm 10 x 1.5 mm 12 x 1 mm 12 x 1.5 mm	G 1/2 B compression fitting (metal ferrule)	6 mm		1.4571 (9 x 1 mm) 316L
		1/2 NPT compression fitting (metal ferrule)			
		Without threaded connection, plain			

Insertion lengths

Protection tube design	Standard insertion length	Min./max. insertion length
Straight, mounting thread, form 2G DIN 43772	160, 250, 400 mm	50 mm / 4,000 mm
Tapered, mounting thread, form 3G DIN 43772	160, 220, 280 mm	110 mm / 4,000 mm
Straight, plain, with/without compression fitting, form 2 DIN 43772	-	50 mm / 4,000 mm
Tapered, plain, with/without compression fitting, form 3 DIN 43772	-	110 mm / 4,000 mm
Tapered, weld-on solid tip, mounting thread, non-standard design	160, 250, 400 mm	75 mm / 4,000 mm
Tapered, plain, weld-on solid tip, with/without compression fitting, non-standard design	-	75 mm / 4,000 mm

Neck lengths

Protection tube design	Standard neck length	Min./max. neck length
Straight, mounting thread, form 2G DIN 43772	130 mm	30 mm / 1,000 mm
Tapered, mounting thread, form 3G DIN 43772	132 mm	30 mm / 1,000 mm
Straight, plain, with compression fitting, form 2 DIN 43772	50 mm	50 mm
Straight, plain, without compression fitting, form 2 DIN 43772	-	-
Tapered, plain, with compression fitting, form 3 DIN 43772	50 mm	50 mm
Tapered, plain, without compression fitting, form 3 DIN 43772	-	-
Tapered, weld-on solid tip, mounting thread, non-standard design	130 mm	30 mm / 1,000 mm
Tapered, weld-on solid tip, with compression fitting, non-standard design	50 mm	50 mm
Tapered, weld-on solid tip, without process connection, non-standard design	-	-

The neck tube is screwed into the connection head. The neck length depends on the intended use. Usually an isolation is bridged by the neck tube. Also, in many cases, the neck tube serves as a cooling extension between the connection head and the medium, in order to protect any possible built-in transmitter from high medium temperatures.

Other versions on request

Measuring insert

Within the TR10-C, the measuring insert of model TR10-A is fitted.

The replaceable measuring insert is made of a vibration-resistant, sheathed measuring cable (MI cable).



Fig. left: standard version

Fig. right: Version with recessed soldering lugs (option)

Only correct measuring insert length and correct measuring insert diameter ensure sufficient heat transfer from protection tube to the measuring insert.

The bore diameter of the protection tube should be a max. 1 mm larger than the measuring insert diameter. Gaps of more than 0.5 mm between protection tube and the measuring insert will have a negative effect on the heat transfer, and they will result in unfavourable response behaviour of the thermometer.

When fitting the measuring insert into a protection tube, it is very important to determine the correct insertion length (= protection tube length for bottom thicknesses of ≤ 5.5 mm). In order to ensure that the measuring insert is firmly pressed down onto the bottom of the protection tube, the measuring insert must be spring-loaded (spring travel: max 10 mm).

Dimensions in mm

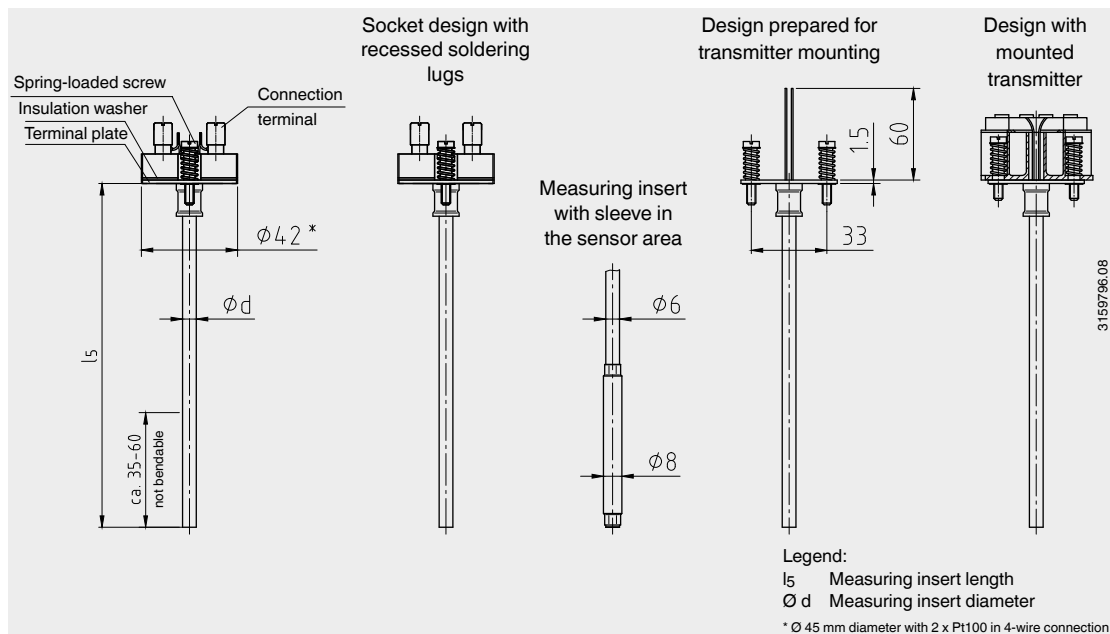

Measuring insert diameter $\varnothing d$ in mm		Index per DIN 43735	Tolerance in mm	Sheath material	
				Standard design	Recessed soldering lugs
3	Standard	30	3 ± 0.05	1.4571, 316L	1.4571
6	Standard	60	$6 \begin{smallmatrix} 0 \\ -0.1 \end{smallmatrix}$	1.4571, 316L	1.4571
8 (6 mm with sleeve)	Standard	-	$8 \begin{smallmatrix} 0 \\ -0.1 \end{smallmatrix}$	1.4571	1.4571
8	Standard	80	$8 \begin{smallmatrix} 0 \\ -0.1 \end{smallmatrix}$	1.4571, 316L	1.4571

Operating conditions

Mechanical requirements

Version	
Standard	6 g peak-to-peak, wire-wound measuring resistor or thin film
Option	Vibration-resistant sensor tip, max. 20 g peak-to-peak, thin-film measuring resistor
	Highly vibration-resistant sensor tip, max. 50 g peak-to-peak, thin-film measuring resistor

The information on the vibration resistance refers to the tip of the measuring insert.

For detailed specifications for vibration resistance of Pt100 sensors, see Technical information IN 00.17 at www.wika.com.

Max. process temperature, process pressure

Depending on:

- Load diagram DIN 43772
- Protection tube design
 - Dimensions
 - Material
- Process conditions
 - Flow rate
 - Medium density

Ambient and storage temperature

-40 ... +80 °C

Other ambient and storage temperatures on request

Thermowell calculation

With critical operating conditions, a thermowell calculation in accordance with Dittrich/Klotter is recommended as a WIKA engineering service.

Note: ASME PTC 19.3 TW-2016 is not applicable for the TR10-C.

For further information, see Technical information IN 00.15 "Strength calculation for thermowells".

Certificates (option)

Certification type	Measurement accuracy	Material certificate ¹⁾
2.2 test report	x	x
3.1 inspection certificate	x	x
DKD/DAkkS calibration certificate	x	-

1) Protection tubes

The different certifications can be combined with each other.

For calibration, the measuring insert is removed from the thermometer. The minimum length (metal part of the probe) for carrying out a measurement accuracy test 3.1 or DKD/DAkkS is 100 mm.

Calibration of shorter lengths on request.

Ordering information

Model / Explosion protection / Further approvals, certificates / Sensor / Accuracy class, range of use of the sensor / Connection housing / Cable entry / Transmitter / Connection to neck tube / Protection tube / Protection tube diameter / Process connection / Protection tube material / Insertion length / Neck length / Certificates / Options

© 04/2003 WIKA Alexander Wiegand SE & Co. KG, all rights reserved.
The specifications given in this document represent the state of engineering at the time of publishing.
We reserve the right to make modifications to the specifications and materials.



WIKAL Alexander Wiegand SE & Co. KG
Alexander-Wiegand-Straße 30
63911 Klingenberg/Germany
Tel. +49 9372 132-0
Fax +49 9372 132-406
info@wika.de
www.wika.de

Operating limits and tolerances of platinum resistance thermometers per DIN EN IEC 60751

WIKA data sheet IN 00.17

General information

Temperature is a measurement for the thermal state of a material - so a measurement of the average kinetic energy of its molecules. A close thermal contact between two bodies is needed in order that these bodies adopt the same temperature (temperature equalisation). The body to be measured should be coupled as closely as possible to the temperature sensor system.

The most established temperature measurement methods are based on material or body properties that change depending on the temperature. One of the most-used methods is the measurement with a resistance thermometer.

This document outlines the recurrent concepts and technologies that apply to all resistance thermometers produced by WIKA.

Standard version

If there are no additional specifications or customer requirements, we will recommend this selection, or we will select this option when offering or producing the thermometer.

Sensor technology

The electrical resistance of a resistance thermometer's sensor changes with the temperature. As the resistance increases when temperature is raised, we refer to it as PTC (Positive Temperature Coefficient).

Pt100 or Pt1000 measuring resistors are normally used for industrial applications. The exact characteristics of these measuring resistors, and the thermometers based on them, are defined in IEC 60751. The most important characteristics are described in this document.

Resistance basic values at 0 °C

Designation	Basic value in Ω
Pt100	100
Pt1000	1,000

Bold: Standard version

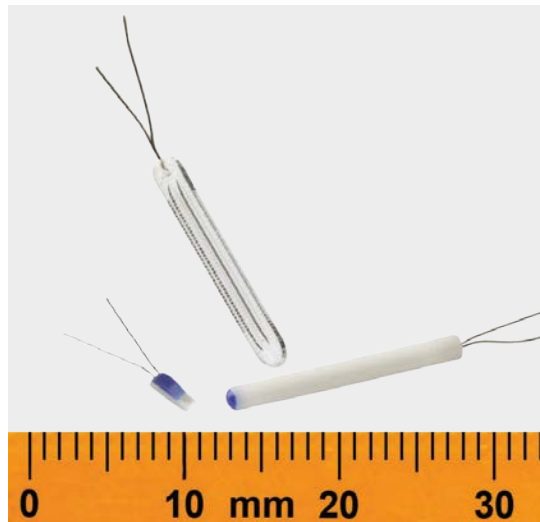

Fig. left: Thin-film measuring resistor

Fig. centre: Glass measuring resistor

Fig. right: Ceramic measuring resistor

Measuring resistor designs

Those measuring resistors used in thermometers can be wire-wound measuring resistors (W = Wire-Wound) or thin-film resistors (F = Thin-Film).

Thin-film measuring resistors (F), standard version

For thin-film measuring resistors, a very thin platinum film is applied to a ceramic carrier plate. Then, connecting wires are attached. Finally, the platinum film and the connecting wire connection are sealed against external effects by a layer of glass.

The thin-film measuring resistor is characterised by

- Temperature range: -50 ... +500 °C ¹⁾
- High vibration resistance
- Very small size
- Good price/performance ratio

Thin-film measuring resistors are the standard design unless the temperature range or an explicit customer request exclude them.

Thin-film measuring resistor

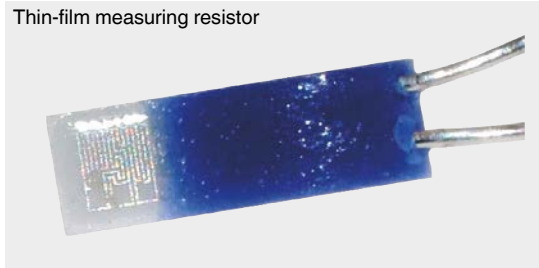

Wire-wound measuring resistors (W)

In this design, a very thin platinum wire is encased within a round protective body. This design has been well-established for decades and is accepted worldwide.

Two subtypes are available that differ in the choice of insulating material.

■ Glass measuring resistor

The bifilar wire of the glass measuring resistor is fused within a glass body.

The glass measuring resistor is characterised by:

- Temperature range: -196 ... +400 °C ¹⁾
- High vibration resistance

Glass measuring resistor



■ Ceramic measuring resistor

The platinum wire of a ceramic measuring resistor is spiral-wound and located in a cylindrical cavity in the protective body.

The ceramic measuring resistor is characterised by:

- Temperature range: -196 ... +600 °C ¹⁾
- Limited vibration resistance

Ceramic measuring resistor

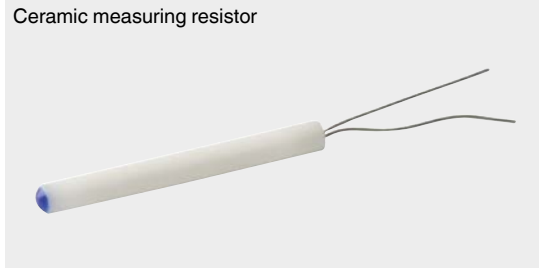

¹⁾ The specifications apply to class B, see also table on page 4

Sensor connection methods

■ 2-wire connection

The lead resistance to the sensor is recorded as an error in the measurement. For this reason, this connection type is not advisable when using Pt100 measuring resistors for tolerance classes A and AA, since the electrical resistance of the connecting cables and their own temperature dependency are fully included in the measuring result and thus falsify it.

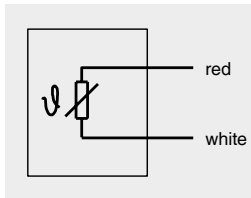

Applications

- Connecting cables up to 250 mm
- Standard when using Pt1000 measuring resistors

■ 3-wire connection (standard version)

The influence of the lead resistance is compensated as far as possible. The maximum length of the connecting cable depends on the conductor cross-section and the compensation options of the evaluation electronics (transmitter, display, controller or process control system).

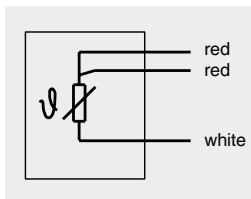

Applications

- Connecting cables up to approx. 30 m

■ 4-wire connection

The influence of the connecting cable on the measuring result is completely eliminated since any possible asymmetries in the connecting cable's lead resistance are also compensated.

The maximum length of the connecting cable depends on the conductor cross-section and the compensation options of the evaluation electronics (transmitter, display, controller or process control system). A 4-wire connection can also be used as a 2-wire or 3-wire connection by disconnecting the unnecessary conductors.

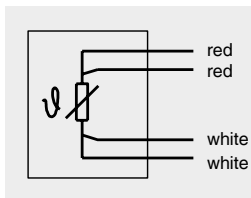

Applications

- Laboratory technology
- Calibration technology
- Tolerance class A or AA
- Connecting cables up to 1,000 m

Dual sensors

In the standard version a single sensor is fitted.

The combination of black and yellow is reserved for an optional second measuring resistor. For certain combinations (e.g. small diameter) dual sensors are not possible for technical reasons.

Relationship between temperature and resistance

For each temperature there is exactly one resistance value.
This clear relationship can be described by mathematical formulae.

For the temperature range -200 ... 0 °C the following applies, irrespective of the resistor design:

$$R_t = R_0 [1 + At + Bt^2 + C(t - 100 \text{ °C}) \cdot t^3]$$

For the temperature range 0 ... 600 °C the following applies:

$$R_t = R_0 [1 + At + Bt^2]$$

Legend:

t = Temperature in °C
R_t = Resistance in ohms at the measured temperature
R₀ = Resistance in ohms at t = 0 °C (e.g. 100 ohms)

For the calculation, the following constants apply

$$A = 3.9083 \cdot 10^{-3} \text{ (°C}^{-1}\text{)}$$

$$B = -5.7750 \cdot 10^{-7} \text{ (°C}^{-2}\text{)}$$

$$C = -4.1830 \cdot 10^{-12} \text{ (°C}^{-4}\text{)}$$

Operating limits and tolerance classes

Both measuring resistor versions (wire-wound/thin-film) differ in the possible tolerances at the operating temperatures.

Class	Temperature range in °C		Tolerance value
	Wire-wound (W)	Thin-film (F)	
B	-196 ... +600	-50 ... +500	±(0.30 + 0.0050 t)¹⁾
A	-100 ... +450	-30 ... +300	±(0.15 + 0.0020 t) ¹⁾
AA	-50 ... +250	0 ... 150	±(0.10 + 0.0017 t) ¹⁾

1) | t | is the numerical value of the temperature in °C irrespective of the sign.

Bold: Standard version

Under certain conditions, thermometers/measuring inserts with built-in measuring resistors can be operated in a temperature range outside the temperature range of the specified class.

The following must be observed regarding the compliance with the tolerance class:

With standard instruments, the class A specified before can no longer be confirmed if the thermometer or measuring insert was operated above or below the class A temperature range. The dwell time is not relevant here.

Even if the temperature is in the range of class A again, the tolerance class of the measuring resistor is no longer defined.

Resistance values and tolerance values with selected temperatures (Pt100)

Tolerance value IEC 60751 for resistance thermometers with film measuring resistors

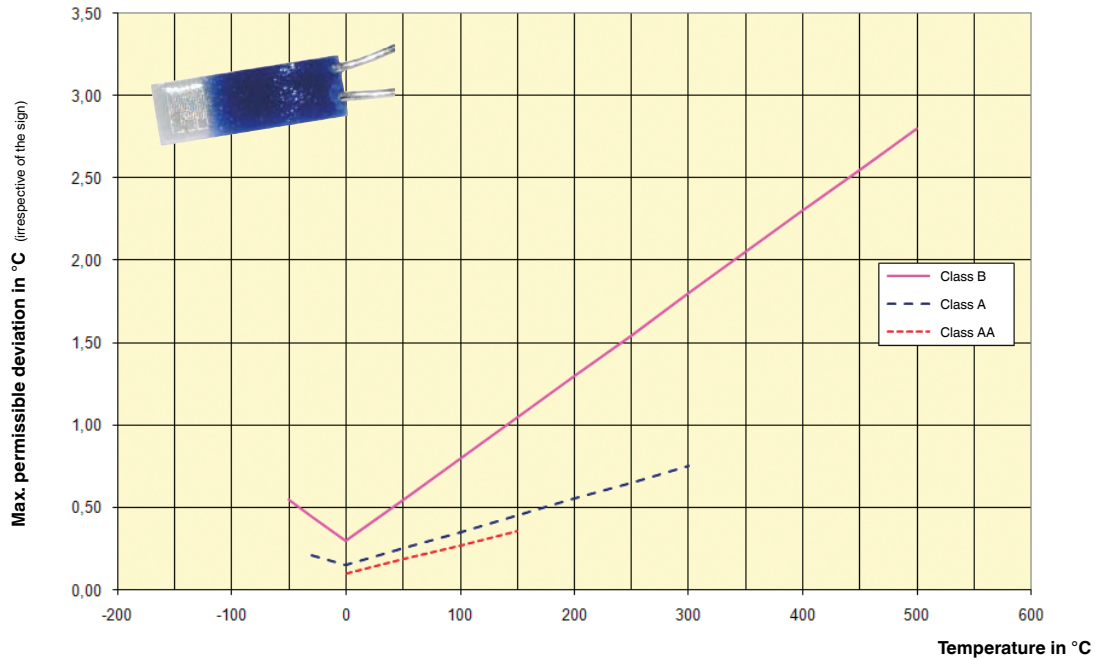

Tolerance value IEC 60751 for resistance thermometers with wire-wound measuring resistors

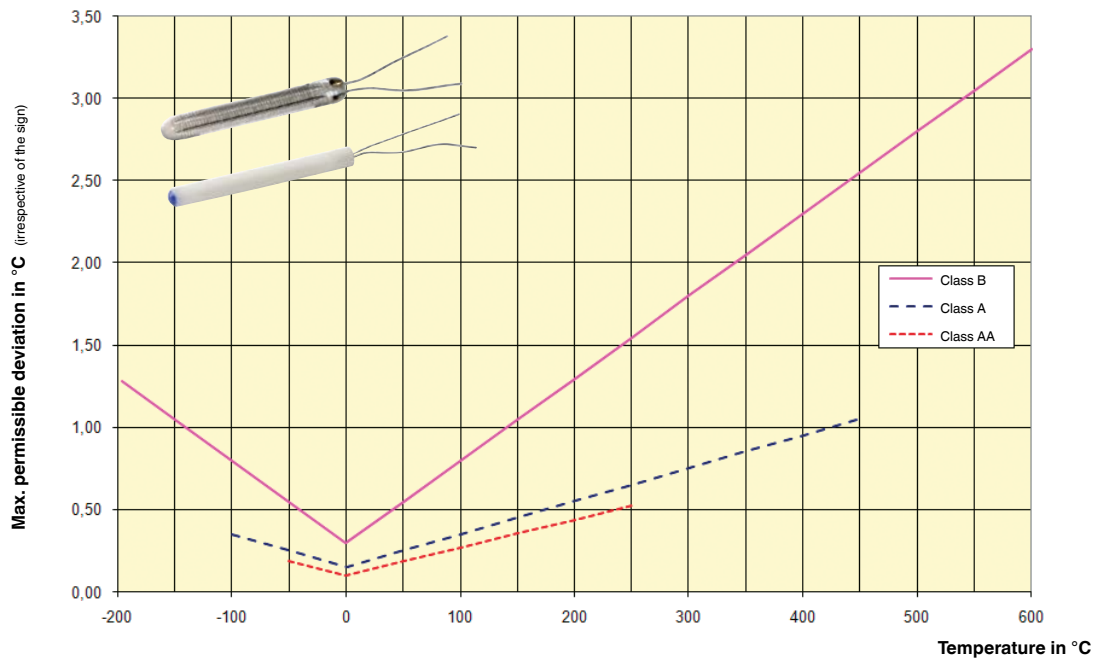

Temperature values and tolerance values with selected resistance values (Pt100)

Resistance value in Ω	Temperature value in $^{\circ}\text{C}$ (ITS 90)		
	Tolerance class B	Tolerance class A	Tolerance class AA
50	-126.07 ... -124.22	-125.55 ... -124.75	-125.46 ... -124.83
80	-51.32 ... -50.22	-51.02 ... -50.52	-50.96 ... -50.58
100	-0.30 ... +0.30	-0.15 ... +0.15	-0.10 ... +0.10
110	25.26 ... 26.11	25.48 ... 25.89	25.54 ... 25.83
150	129.50 ... 131.40	130.04 ... 130.86	130.13 ... 130.77
200	264.72 ... 267.98	265.67 ... 267.03	265.80 ... 266.90
300	554.60 ... 560.78	556.42 ... 558.95	556.64 ... 558.74

This table can be used to check the evaluation electronics, e.g. by means of a decade resistor:

This means if the sensor or the measuring resistor is simulated by a decade resistor, the evaluation electronics must display a temperature value within the limit values specified above.

Resistance values and tolerance values with selected temperatures (Pt100)

Temperature in $^{\circ}\text{C}$ (ITS 90)	Resistance value in Ω		
	Tolerance class B	Tolerance class A	Tolerance class AA
-196	19.69 ... 20.80	-	-
-100	59.93 ... 60.58	60.11 ... 60.40	-
-50	80.09 ... 80.52	80.21 ... 80.41	80.23 ... 80.38
-30	88.04 ... 88.40	88.14 ... 88.30	88.16 ... 88.28
0	99.88 ... 100.12	99.94 ... 100.06	99.96 ... 100.04
20	107.64 ... 107.95	107.72 ... 107.87	107.74 ... 107.85
100	138.20 ... 138.81	138.37 ... 138.64	138.40 ... 138.61
150	156.93 ... 157.72	157.16 ... 157.49	157.91 ... 157.64
250	193.54 ... 194.66	193.86 ... 194.33	193.91 ... 194.29
300	211.41 ... 212.69	211.78 ... 212.32	-
450	263.31 ... 265.04	263.82 ... 264.53	-
500	280.04 ... 281.91	-	-
600	312.65 ... 314.77	-	-

This table represents the calibration process with predefined temperatures.

This means if a temperature standard is available, the resistance value of the test item must lie within the limits specified above.

Vibration resistance of resistance thermometers

In accordance with IEC 60751, the design of a resistance thermometer can be influenced by vibration-induced accelerations that can be up to 3 g (30 m/s²) and occur in a frequency range from 10 ... 500 Hz.

The vibration resistance data listed in the data sheets of the electrical thermometers from WIKA refer to the "peak-to-peak" value.

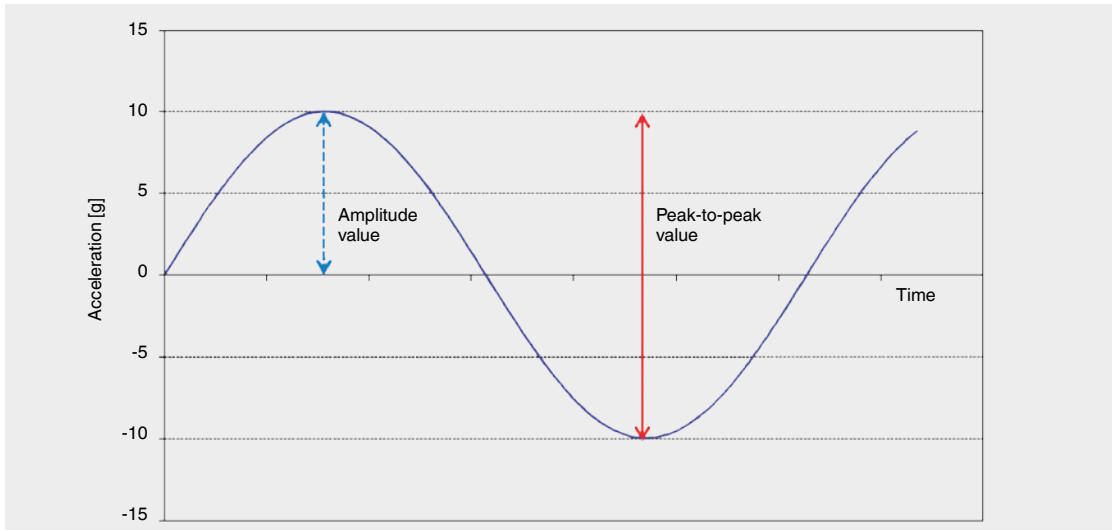

Version	Required vibration resistance per IEC 60751 in g ¹⁾ (peak-to-peak)	Determined vibration resistance WIKA per IEC 60751 in g ¹⁾ (peak-to-peak)
Standard	3	6
Vibration resistant (optional, thin-film measuring resistor)	-	20
Highly vibration resistant (special construction, thin-film measuring resistor)	-	50

1) 9.81 m/s²

Measuring resistor		Vibration resistance (peak-to-peak)					
		Ø 3 mm (MI cable)			Ø 6 mm (MI cable)		
		6 g	20 g	50 g	6 g	20 g	50 g
Thin-film (F)	1 x Pt100 / 1 x Pt1000	x	x	x	x	x	x
	2 x Pt100 / 2 x Pt1000	x	x	-	x	x	x
Thin-film, face-sensitive (FS)	1 x Pt100 / 1 x Pt1000	x	-	-	x	-	-
Wire-wound (W)	1 x Pt100 / 1 x Pt1000	x	-	-	x	-	-
	2 x Pt100 / 2 x Pt1000	x	-	-	x	-	-

The vibration resistance data listed in the data sheets of the electrical thermometers from WIKA only refer to the sensor tip.

© 01/2010 WIKA Alexander Wiegand SE & Co. KG, alle Rechte vorbehalten.
The specifications given in this document represent the state of engineering at the time of publishing.
We reserve the right to make modifications to the specifications and materials.

11/2020 EN

WIKA data sheet IN 00.17 · 11/2020

Page 8 of 8



WIKA Alexander Wiegand SE & Co. KG
Alexander-Wiegand-Straße 30
63911 Klingenberg/Germany
Tel. +49 9372 132-0
Fax +49 9372 132-406
info@wika.de
www.wika.de