

Flowmeter

»FLUX« series

MAX

Art. No. 148202

Type No. 9000991611

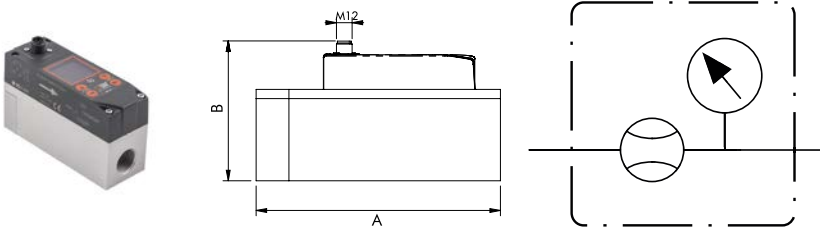

Exemplary illustration

Thermal flowmeters of the »FLUX« series are the ideal solution for monitoring changes in flow and consumption, as well as for measuring leaks and energy efficiency. All flowmeters come with an M12 connection for power supply and signal management plus an analogue output that can be set to either voltage or current. For best results, use a straight pipe with a constant cross section and a minimum length according to the table (see data sheet). If straight piping is not installed, the accuracy may vary from what is stated.

They are available in two main versions: with or without built-in display.

The versions with display provide an intuitive user interface for several real-time information, including:

- flow rate, pressure and temperature
- graphs showing instant and cumulative quantities
- power consumption to generate the measured flow

The wireless versions can communicate with Ethernet networks and mobile devices via Bluetooth® through the dedicated „Metal Work FluxUP“ app. In addition to displaying the measured values in real time, this app can be used to change all flowmeter settings and display the relevant data.

»FLUX« of sizes 1 and 2 can be mounted on »SYNTESI« maintenance units of sizes 1 and 2. If the device is fitted with a Syntesi® filter, the SYN filter parameter must be enabled in the system menu to guarantee the stated accuracy (function available only for the version with display). If the »SYNTESI« is fitted at the outlet of the »FLUX«, the straight pipe on the inlet side must still be guaranteed. »FLUX« of sizes 3 and 4 are installed directly in the pipes. Due to their size and weight, they are not intended for direct installation on maintenance units.

Technical data

Series	FLUX
Size	1
Operating pressure	0 - 10 bar
Temperature range	0 to 50 °C
Connection	G 1/2 IT
Measuring range	0 NI/min to 2000 NI/min
Analogue output	0 - 10 V / 4 - 20 mA
Digital output	an allocated bit
Display	with
Pressure sensor	with

Technical data

IO-Link	with
Function	flowmeter, flow switch, pressure gauge/switch, thermometer
Measured values output	via cable and display
WiFi	with
Compatible with app	yes
Medium	filtered, unlubricated compressed air and neutral gases
Required purity class in accordance w. ISO 8573-1	4.7.3
Housing	aluminium
Supply voltage range	12 -10 % to 24 +30 % V DC
Operating voltage	10.8 - 31.2 V DC
Max. admissible voltage	32 V DC *
Hysteresis	adjustable
Flow direction	unidirectional
Measuring system	thermal
Protection IP	IP65
A	116.0 mm
B	79.0 mm

Before appliance \geq 150 mm straight section, after appliance \geq 50mm.

*IMPORTANT! Voltage greater than 32 V DC will damage the system irreparably.

Commercial data

Customs tariff number	90261021
Country of origin	IT
eCl@ss 5.1.4	27200490
eCl@ss 9.0	27200490
UNSPSC_Code_v190501	20121904
UNSPSC_CodeDesc_v190501	Flow measurement equipment

FLOWMETER SERIES FLUX

The flowmeters in the FLUX series are the ideal solution for measuring the flow rate of compressed air in pneumatic systems.

Made of an anodised aluminium body from 1/2" to 2" threaded ports, they can measure flow rates of up to 15,000 NI/min.

Available in two main versions: with or without built-in display.

The version with display provides an intuitive user interface for real-time several information, including:

- flow rate, pressure and temperature;
- graphs showing instant and cumulative quantities;
- power consumption to generate the measured flow.

This version also integrates a pressure/temperature transducer that uses an advanced software algorithm to minimise measurement error within the operating range.

All flowmeters come have an M12 connector for power supply and signal management plus an analogue output that can be set to either voltage or current; the models with display also feature a configurable digital output (on the flow rate, pressure or total consumption).

They can be powered with variable voltage ranging from 12VDC to 24VDC and act as either a flowmeter and flow switch; additionally,

the display versions can be used as either a pressure gauge or pressure switch. Internal air channels are designed to ensure an accurate flow rate reading at all times without creating any pressure drop between the instrument inlet and outlet.

The wireless versions can communicate with Ethernet networks (via MQTT protocol) and mobile devices (smartphones and tablets) via Bluetooth®, through the dedicated App "Metal Work FluxUP". In addition to displaying measured values in real time, through this App, you can change all flowmeter settings and view the relevant data.



UNITS

FLOWMETER SERIES FLUX

TECHNICAL DATA		FLUX 1	FLUX 2	FLUX 3	FLUX 4
Measured flow range	NI/min	0 to 2000	0 to 4000	0 to 8000	0 to 15000
Fluid		Compressed air free of any lubricants and inert gases			
Fluid temperature	°C	0 to 50			
Direction of flow		Unidirectional			
Measuring method		Thermal			
Working pressure range	bar	0 to 10			
	MPa	0 to 1			
	psi	0 to 145			
Pressure drop		None			
Temperature range	°C	0 to 50			
Threaded ports		1/2"	1"	1 1/2"	2"
Degree of protection		IP65			
Weight	g	585	705	1975	4000
IO-Link supply voltage range	VDC	15 - 27 (with IO-Link Master)			
Current consumption	mA	80 mA (at 24VDC)			
Power supply voltage range in the analogue version	VDC	12 -10% 24 +30%			
Maximum admissible voltage	VDC	32 ▲			
Current absorption	mA	min 50 - max 120			
DISPLAY					
Instant flow rate	NI/min	0 to 2300	0 to 4600	0 to 8800	0 to 16500
Cumulative flow rate	NI	999.999.999			
	Nm³	999.999			
	Nft³	35.320.000			
Pressure ■	bar	0 to 10			
Resolution	bar	0.01			

▲ IMPORTANT! Voltage greater than 32VDC will damage the system irreparably.

■ In versions with pressure transducer.

TECHNICAL DATA	FLUX 1	FLUX 2	FLUX 3	FLUX 4
PRECISION ●				
Flow rate	0 to 100% of the full scale			
Measuring range	from 0 to 20% of the FS - better than ±1% of the FS			
Single unit display accuracy	from 20% to 100% of the FS - better than ±3% of the FS			
Display accuracy of unit installed in an SY unit *	from 0 to 20% of the FS - better than ±2% of the FS	from 20% to 100% of the FS - better than ±6% of the FS	-	-
Repeatability	±1% of the FS			
Temperature characteristic	Automatic compensation of fluid temperature from 0 to 50° Between 0 and 15°C and between 35 and 50°C ±0.6% of the FS every °C			
Version with pressure transducer	Without compensation, between 0 and 15°C and between 35 and 50°C ±1.2% of the FS every °C			
Version without pressure transducer				
Pressure				
Measuring range	bar 0 to 10			
Display accuracy	±2% of the FS			
ANALOGUE OUTPUT				
Output signal	Analogue output powered 0 to 10 VDC or 0 to 5 VDC (I max 20 mA)			
	Analogue output current 4 to 20 mA			
	Max. load impedance 500 Ω			
Analogue output accuracy	±0.1% of the value read			
DIGITAL OUTPUT †				
Maximum current	mA n° 1 open collector output NC / NO - PNP / NPN 100 mA			
Residual voltage	VDC 20 mV (with load)			
Operating mode, if set on flow rate	Level switch, Band switch, Value switch, Cyclic pulse			
Min. accumulated volume by pulse (pulse width 100 msec)	Nl 10	Nm³ 20	Nl 30	Nl 60
	Nf³ 1	Nf³ 1	Nf³ 1	Nf³ 1
	Nf³ 1	Nf³ 1	Nf³ 1	Nf³ 2
Response mode, with pressure mode setting	Level switch, Band switch			
Hysteresis	Adjustable			
Short-circuit protection at output	Yes			
DIGITAL INPUT ◆				
Type of input	n° 1 input for the reset of the consumption counters NO - PNP/NPN			
Activation time	Voltage 12 -10% 24 +30% min 1 sec			

UNITS
FLOWMETER SERIES FLUX

● Accuracy referred to compressed air gas, at a pressure of 5 bar and a fluid temperature of 25°C ±10°C.

* In order to guarantee the stated measurement accuracy and to prevent lubricant residues from damaging the measurement sensor, a filter has to be mounted at the FLUX inlet.

† If the device is fitted with a Syntesi[®] filter, the SYN filter parameter must be enabled in the system menu to guarantee the stated accuracy (function available only for the version with display).

◆ Version without display: the digital input selects the type of analogue output from 0 to 10 V and 4 to 20 mA.

† Available only for version with display.

COMPONENTS

- ① BODY: anodized aluminium
- ② INLET BUSHING: anodized aluminium
- ③ FLOW RECTIFIER DISC: passivated aluminium
- ④ CONNECTOR M12: technopolymer
- ⑤ ELECTRONIC BOARD
- ⑥ FLOW SENSOR
- ⑦ COVER: technopolymer
- ⑧ GASKETS: NBR

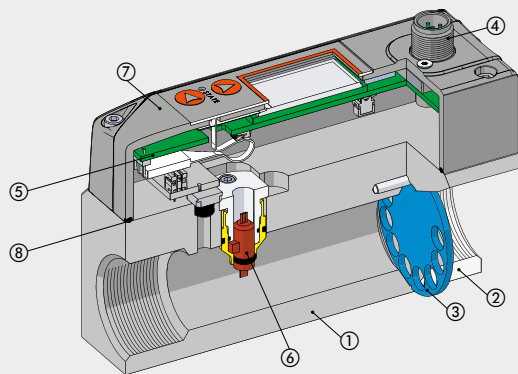

WIRING DIAGRAMS

Wiring diagram, analogue version

M12 male connector, A encoding



Pin	Function description	Lead colour
1	+24VDC power supply	Brown
2	Digital output	White
3	0VDC power supply	Blue
4	Digital input	Black
5	Analogue output	Gray

Wiring diagram, IO-Link version

M12 male connector, A encoding



Port Class A
 1 = L+
 2 = NC
 3 = L-
 4 = C/Q
 5 = NC

Pin	Signal	Description of Port Class A	Lead colour
1	L+	+24VDC power supply	Brown
2	NC	/	White
3	L-	0VDC power supply	Blue
4	C/Q	IO-Link communication	Black
5	NC	/	Gray

WIRELESS CONNECTION

With the Wireless versions, you can establish a connection to a Wi-Fi® network via an access point or gateway to monitor and collect all the measured gas values.

Connection to a MQTT broker via an access point

MQTT

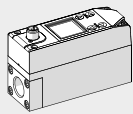

Broker MQTT



The "Metal Work FluxUp" App allows you to connect, via Bluetooth, from Android® and iOS® smartphones, to the Metal Work flowmeters of the FLUX series, equipped with a wireless interface.

Through "Metal Work FluxUp" it is possible to view in real time all the data recorded by FLUX and set all the operating parameters.

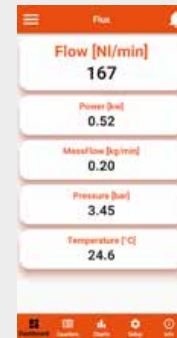

PNEUMATIC CONNECTION

To connect the inlet side, use a straight pipe* with a minimum length as per the table. If straight piping is not installed, the accuracy may vary from what is stated.

* **Straight pipe:** the pipe must be straight with a constant cross-section.

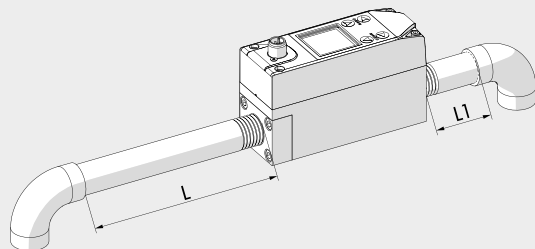

Pipe length

	L Inlet	L1 Outlet
FLUX 1	≥150 mm	≥50 mm
FLUX 2	≥200 mm	≥50 mm
FLUX 3	≥300 mm	≥100 mm
FLUX 4	≥300 mm	≥100 mm

UNITS

FLOWMETER SERIES FLUX

FIXING OPTIONS

FLUX 1 - 2 - 3

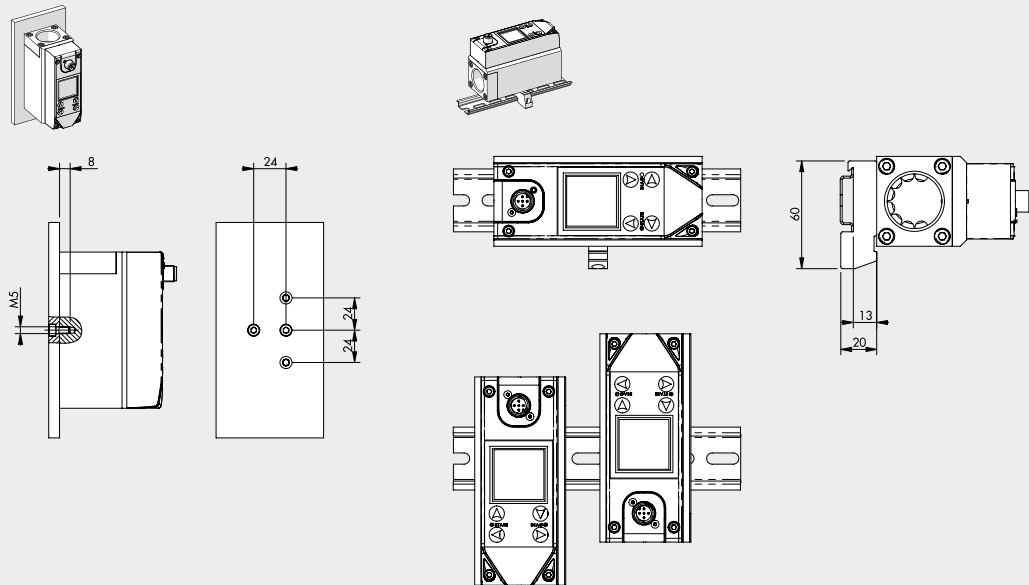

Wall mounting by means M5 screws.

DIN rail mounting with bracket code 900099A001, using the M5x14 screws provided.

FLUX 4

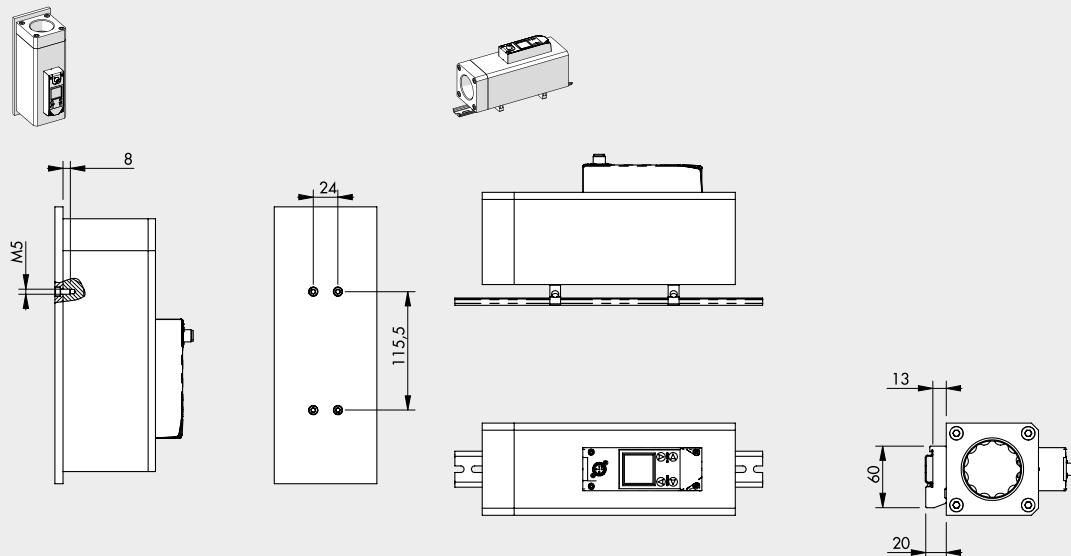

Wall mounting by means M5 screws.

DIN rail mounting with bracket code 900099A001, using the M5x14 screws provided.

N.B.: For this type of fixing use n. 2 connection brackets.

UNITS

FLOWMETER SERIES FLUX

ASSEMBLY DIAGRAM OF FLUX 1 - 2 WITH SYNTESI[®]

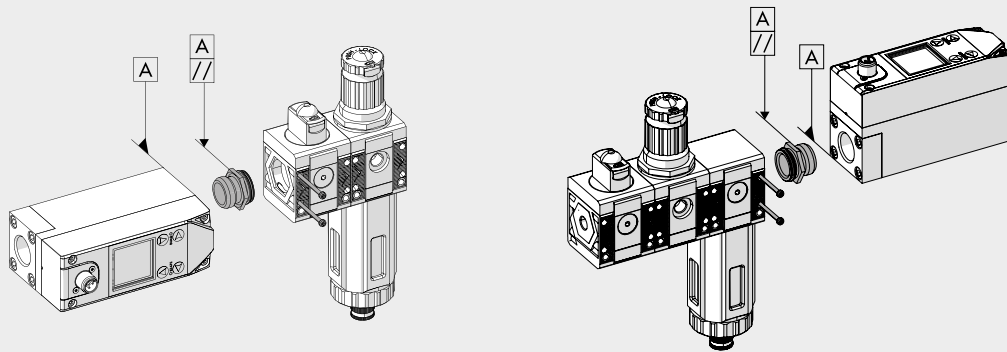

- 1) Tighten the connection bushing on the flowmeter until it is flush (it is advisable to use sealant on the male thread of the bushing to ensure a perfect seal).
- 2) Unscrew the bushing slightly until two surfaces of the hexagon are parallel to the body of FLUX.
- 3) Insert the bushing into the Syntesi[®] unit.
- 4) Tighten the two self-tapping screws in the Syntesi[®] unit to a torque of 0.4 Nm for size 1 and torque 2.5 Nm for size 2.

UNITS

FLUX 1 + SYNTESI[®] 1

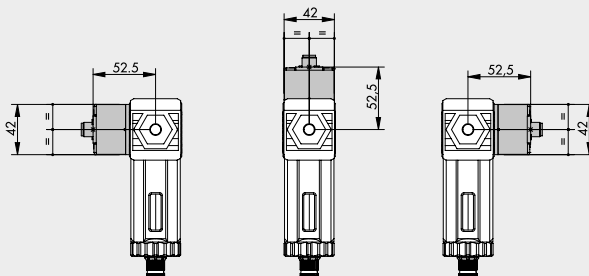

FLUX 2 + SYNTESI[®] 2

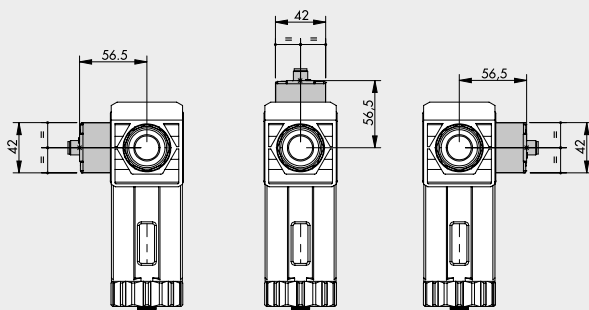

N.B.: If the FLUX is used downstream a Syntesi[®] filter, fit it in one of the three positions shown in the figure.

DIMENSIONS AND ORDERING CODES FLUX 1 - 2

FLUX 1

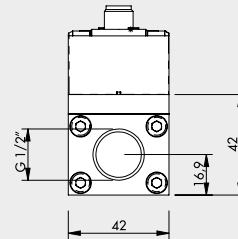
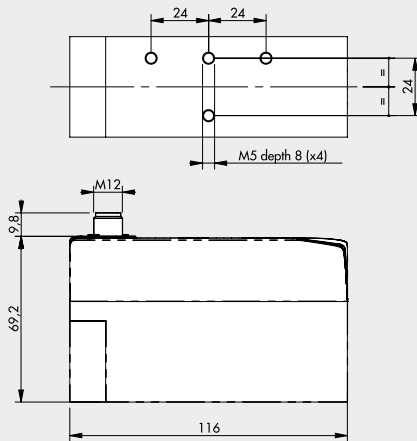
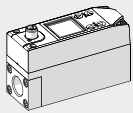

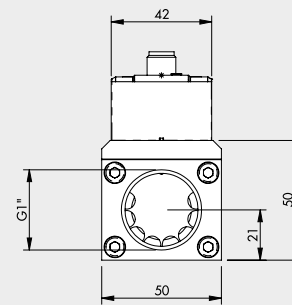
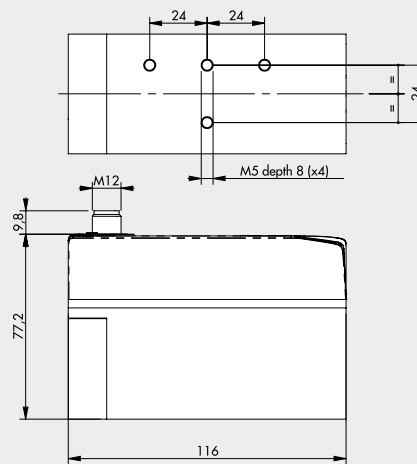
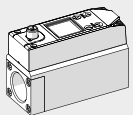

FLUX 2



UNITS

FLOWMETER SERIES FLUX

Symbol	Code	Description
	9000991000	Flowmeter FLUX 1, coupling 1/2", analog output 0-10V 4-20 mA
	9000991200	Flowmeter FLUX 1, coupling 1/2", IO-Link
	9000992000	Flowmeter FLUX 2, coupling 1", analog output 0-10V 4-20 mA
	9000992200	Flowmeter FLUX 2, coupling 1", IO-Link
	9000991510	Flowmeter FLUX 1, coupling 1/2", digital output PNP 0-10V 4-20 mA, with display and pressure sensor
	9000991511	Flowmeter FLUX 1, coupling 1/2", digital output PNP 0-10V 4-20 mA, with display, pressure sensor and Wi-Fi®
	9000991610	Flowmeter FLUX 1, coupling 1/2", IO-Link with display and pressure sensor
	9000991611	Flowmeter FLUX 1, coupling 1/2", IO-Link with display, pressure sensor and Wi-Fi®
	9000992510	Flowmeter FLUX 2, coupling 1", digital output PNP 0-10V 4-20 mA, with display and pressure sensor
	9000992511	Flowmeter FLUX 2, coupling 1", digital output PNP 0-10V 4-20 mA, with display, pressure sensor and Wi-Fi®
	9000992610	Flowmeter FLUX 2, coupling 1", IO-Link with display and pressure sensor
	9000992611	Flowmeter FLUX 2, coupling 1", IO-Link with display, pressure sensor and Wi-Fi®

DIMENSIONS AND ORDERING CODES FLUX 3 - 4

FLUX 3

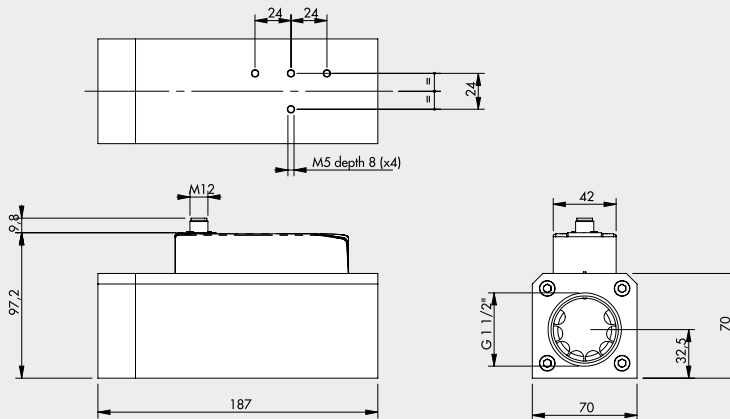
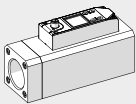

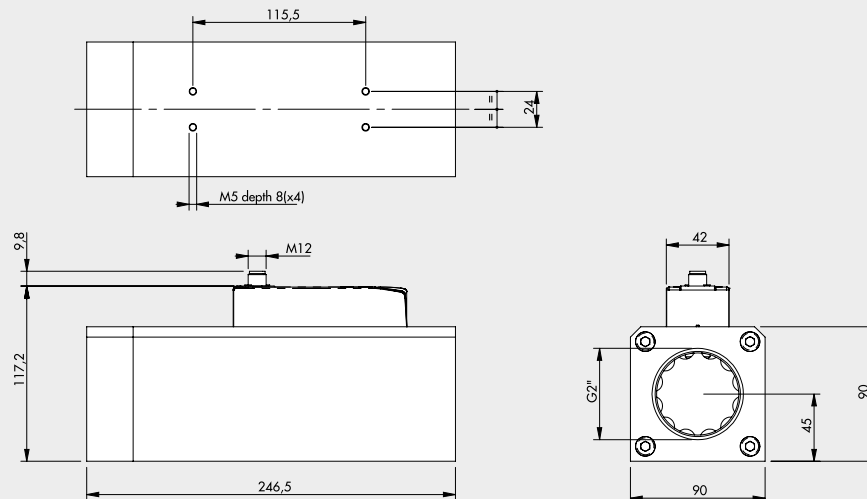
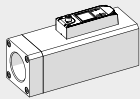

FLUX 4



UNITS

FLOWMETER SERIES FLUX

Symbol	Code	Description
	9000993000	Flowmeter FLUX 3, coupling 1 1/2", analog output 0-10V 4-20 mA
	9000993200	Flowmeter FLUX 3, coupling 1 1/2", IO-Link
	9000994000	Flowmeter FLUX 4, coupling 2", analog output 0-10V 4-20 mA
	9000994200	Flowmeter FLUX 4, coupling 2", IO-Link
	9000993510	Flowmeter FLUX 3, coupling 1 1/2", digital output PNP 0-10V 4-20 mA, with display and pressure sensor
	9000993511	Flowmeter FLUX 3, coupling 1 1/2", digital output PNP 0-10V 4-20 mA, with display, pressure sensor and Wi-Fi®
	9000993610	Flowmeter FLUX 3, coupling 1 1/2", IO-Link with display and pressure sensor
	9000993611	Flowmeter FLUX 3, coupling 1 1/2", IO-Link with display, pressure sensor and Wi-Fi®
	9000994510	Flowmeter FLUX 4, coupling 2", digital output PNP 0-10V 4-20 mA, with display and pressure sensor
	9000994511	Flowmeter FLUX 4, coupling 2", digital output PNP 0-10V 4-20 mA, with display, pressure sensor and Wi-Fi®
	9000994610	Flowmeter FLUX 4, coupling 2", IO-Link with display and pressure sensor
	9000994611	Flowmeter FLUX 4, coupling 2", IO-Link with display, pressure sensor and Wi-Fi®

ACCESSORIES

STRAIGHT CONNECTOR

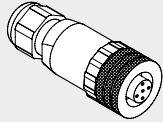

Code W0970513001
Description 5-PIN M12x1 straight connector

STRAIGHT CONNECTOR WITH WIRE

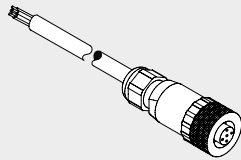

Pin	Cable color
1	Brown
2	White
3	Blue
4	Black
5	Grey

Code W0970513002
Description 5-PIN M12x1 straight connector with wire L = 5 m

90° CONNECTOR

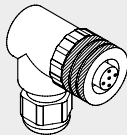

Code W0970513003
Description M12x1 5-PIN 90° connector

90° CONNECTOR WITH WIRE

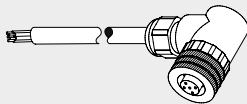

Pin	Cable color
1	Brown
2	White
3	Blue
4	Black
5	Grey

Code W0970513004
Description M12x1 5-PIN 90° connector with wire L = 5 m

CONNECTION BRACKETS ON THE BAR (DIN EN50022)

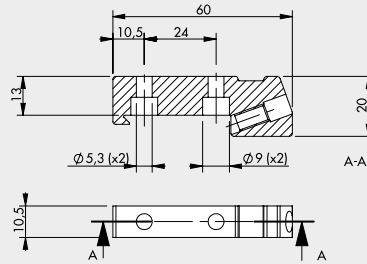

Code 900099A001
Description Connection brackets on DIN bar, FLUX 1 - 4

Note: complete with 2 M5x14 screws and 1 M6 grub screw

SY1 - SY2 KIT FOR CONNECTION

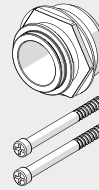

Code 900099A002 Adapter FLUX 1 - SY1
900099A003 Adapter FLUX 2 - SY2

Max torque for screw, 0.4 Nm for SY1
Max torque for screw, 2.5 Nm for SY2

NOTES

UNITS

FLOWMETER SERIES FLUX

Accessories

	Art. No.	Type No.
Straight socket M12 x 1 mm	148191	W0970513001
Electric connection cable, straight wall outlet, 5 m cable	101132	533.901
90° angle socket M12 x 1 mm	148239	W0970513003
Electric connection cable, 90° elbow wall outlet, 5 m cable	101133	533.902
Adapter for DIN rail for series »FLUX« size 1-4	148236	900099A001
Adapter for series »FLUX« size 1 - »SYNTESI« size 1	148237	900099A002