



EB 80 electro-pneumatic system



EB 80 ELECTRO-PNEUMATIC SYSTEM

EB 80 is defined as an electro-pneumatic system as it would be simplistic to use the term "solenoid valve island". In effect, a single assembly can combine solenoid valves of all types, multi-position bases, pneumatic and electric supplies arranged as desired in a system, digital or analogue input or output signal control modules and much more besides.

The EB 80 system is protected by numerous patents and utility models, which enhance the most innovative design solutions.

The possible combinations are endless, but the most amazing thing is that they can be obtained using a small number of basic components.

In order to achieve this objective, a single size of small yet high-performance valves to cover the vast majority of applications was conceived.





A single electronic control unit is provided when supplying 12VDC or 24VDC valves with multi-pole cables or with a field bus for each protocol.

All EB 80 versions come with an efficient diagnostic system.

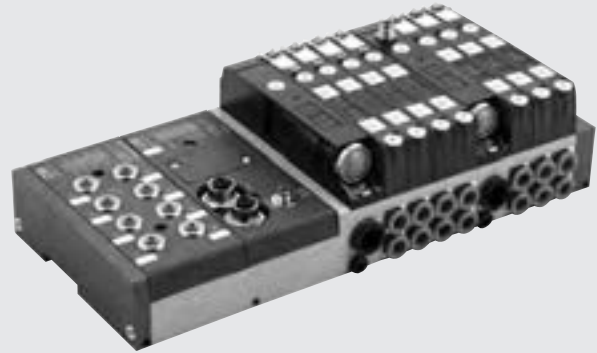
The EB 80 catalogue consists of a first overall introductory chapter followed by a chapter for each subsystem.

NSF H1-certified grease is used to lubricate the valve spool and seals.



TECHNICAL DATA							
Supply voltage range	VDC	12 -10%		24 +30%			
Minimum operating voltage	VDC	10.8 *					
Maximum operating voltage	VDC	31.2					
Maximum admissible voltage	VDC	32 ***					
Power for each controlled pilot	W	3 for 15 ms, then holding 0.3					
Drive (for multi-pole)		PNP or NPN					
Solenoid rating		100% ED					
Solenoid valve supply power		See chapter "Electrical connection - E"					
Signal module supply power		See chapter "Signal module - S"					
Protection		Overload and short-circuit protected solenoid pilot Output					
Diagnostics		See chapter "Electrical connection - E"					
Maximum number of solenoid pilots		21 or 38 multi-pole connection; field bus 128					
Ambient temperature	°C	-10 to + 50 (at 8 bar)					
	°F	14 to 122 (at 8 bar)					
Operating pressure		5/2 and 5/3				2/2 and 3/2	
Non-assisted valves	bar	3 to 8				3.5 to 8	
	MPa	0.3 to 0.8				0.35 to 0.8	
	psi	43 to 116				51 to 116	
Assisted valves	bar	Vacuum to 10					
	MPa	Vacuum to 1					
	psi	Vacuum to 145					
Servo pressure	bar	3 to 8		min. (see graph on page B2.53) / max. 8			
	MPa	0.3 to 0.8		min. (see graph on page B2.53) / max. 0.8			
	psi	43 to 116		min. (see graph on page B2.53) / max. 116			
Valve flow rate, at 6.3 bar ΔP 1 bar		Ø 4 (5/32")	Ø 6	Ø 8 (5/16")	Ø 1/4"	Ø 10 **	Ø 3/8" **
	valve 2/2 NI/min	350	430	500	430	-	-
	valve 3/2 NI/min	350	600	700	600	1250	1250
	valve 5/2 NI/min	350	650	800	650	1250 - 1400	1250 - 1400
	valve 5/3 NI/min	350	460	500	460	1000 - 1250	1000 - 1250
	valve V3V (R) NI/min	-	-	-	-	1000	1000
Actuation response time (TRA) / reset response time (TRR) at 6 bar							
	TRA/TRR valve 2/2 and 3/2 ms	14 / 28					
	TRA/TRR valves 5/2 monostable and shut-off valve ms	12 / 45					
	TRA/TRR valve 5/2 bistable ms	12 / 14					
	TRA/TRR valve 5/3 ms	15 / 45					
	TRA/TRR valve 3/2 high flow ms	13 / 36					
Fluid		Unlubricated air					
Air quality required		ISO 8573-1 class 4-7-3					
Degree of protection		IP65 (with connectors connected or plugged if not used)					
Category ATEX		Ex II 3G Ex ec IIC T5 Gc X -10°C<Ta<50°C Ex II 3D Ex tc IIIC T100°C Dc X					
Certifications		 -  -  us - 					

* Minimum voltage 10.8VDC required at solenoid pilots. Check the minimum voltage at the power supply output using the calculations shown on page B2.24

** Using high-flow valves or connected valves - see pages B2.54

*** IMPORTANT! Voltage greater than 32VDC will damage the system irreparably.

N.B.: Refer to the chapter of each EB 80 sub-assembly for specific technical data.

CERTIFICATIONS

The **UL** certification for the part concerning only CSA (Canadian market) is bound to the following conditions of use:

- environment temperature: max 45°C
- ED max 70%

If non-adjointing valves are used, ED max can reach 100% (environment temperature max 45°C)

COMPONENTS

EB 80 systems are identified by a set of sub-assemblies:

- S** I/O Signal Modules
- E** Electrical connection
- P** Pneumatic supply
- B** Bases for solenoid valves; the valves are fixed on the bases
- M** InterMediate Modules
- C** Closed end-plate

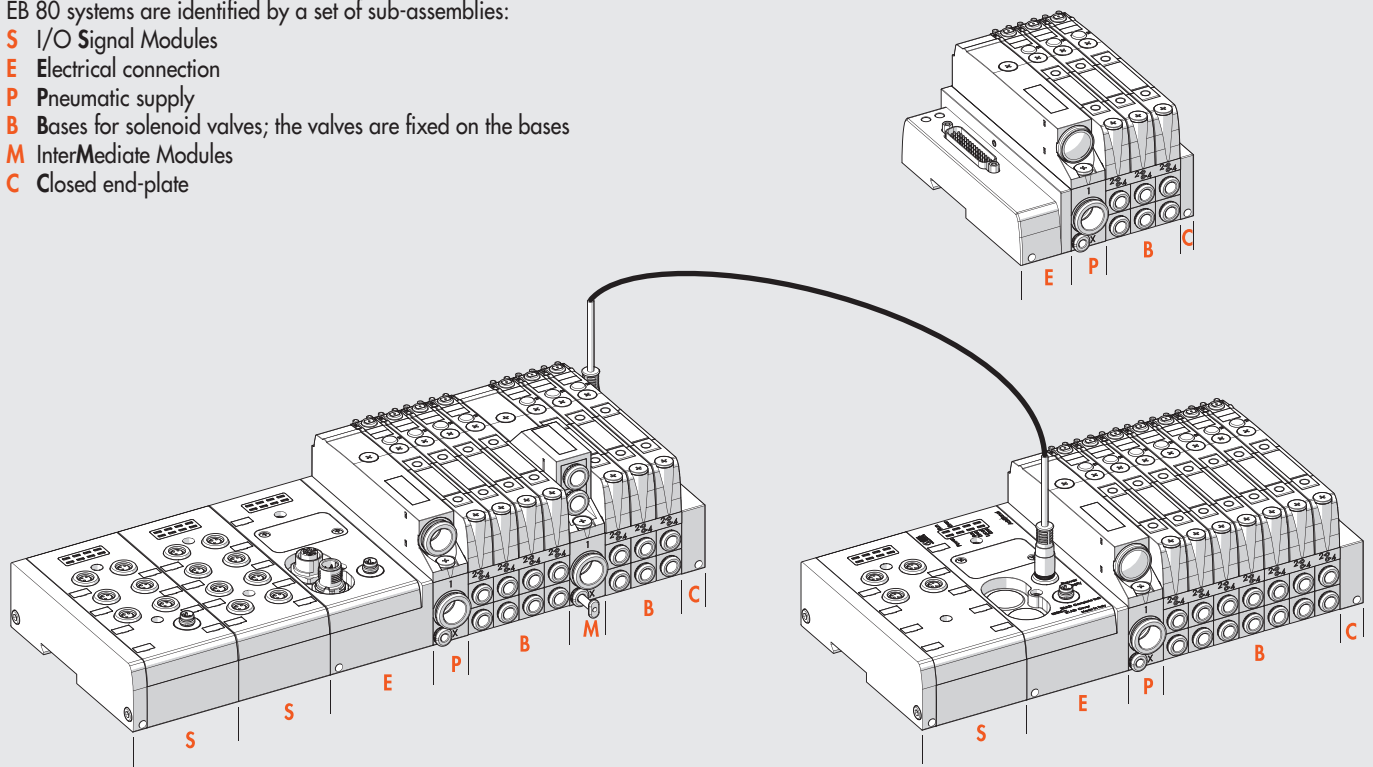

COMPONENTS – SOLENOID VALVE AND BASE

- ① BASE: technopolymer
- ② VALVE BODY: technopolymer
- ③ CONTROL: technopolymer
- ④ BASE: technopolymer
- ⑤ SPOOL: chemically nickel-plated aluminium
- ⑥ CONTROL PISTON: Stainless steel and NBR
- ⑦ SPRING: Oteva® steel and Dacromet treatment
- ⑧ SOLENOID VALVE
- ⑨ ELECTRONIC BOARD
- ⑩ LED light display: technopolymer
- ⑪ MANUAL CONTROL: nickel-plated brass
- ⑫ SCREW SECURING VALVE TO THE BASE: zinc-plated steel
- ⑬ SPOOL GASKET: NBR
- ⑭ Push-in fitting CARTRIDGE for port 2
- ⑮ Push-in fitting CARTRIDGE for port 4

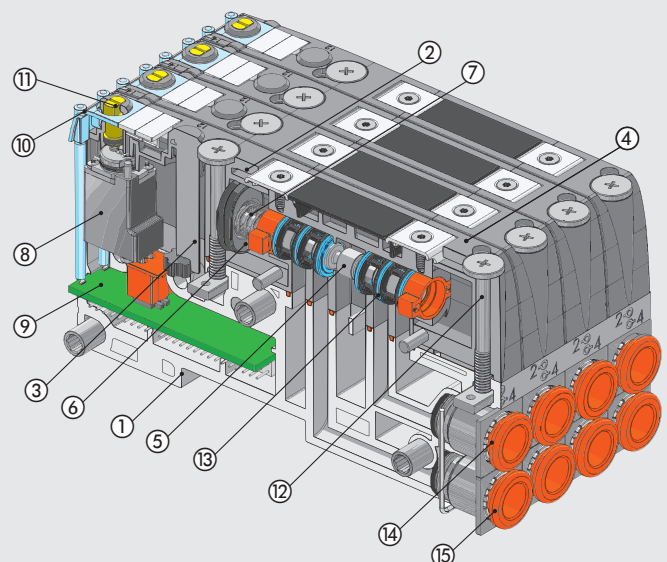

THE EB 80 WORLD

ELECTRICAL CONNECTION - E

E025	E044	E0EN	E0EC	E0PN	E0CN	E0PB	E0PL	E0IO	E0LK	E0CC	E0AD
EB 80 25-pin electrical connection	EB 80 44-pin electrical connection	EB 80 Electrical connection EtherNet/IP	EB 80 Electrical connection EtherCAT	EB 80 Electrical connection Profinet IO	EB 80 Electrical connection CANopen	EB 80 Electrical connection Profibus-DP	EB 80 Electrical connection Ethernet POWERLINK	EB 80 Electrical connection IO-Link 32 IN/32 OUT	EB 80 Electrical connection IO-Link 64 OUT	EB 80 Electrical connection CC-Link IE Field Basic	Additional electrical connection EB 80
See page B2.26	See page B2.26	See page B2.39	See page B2.39	See page B2.39	See page B2.39	See page B2.39	See page B2.39	See page B2.39	See page B2.39	See page B2.39	See page B2.44

SIGNAL MODULE - S

S01	S02	S03	S04	S05	S06	S07	S08
EB 80 module with 8 M8 digital inputs	EB 80 module with 8 M8 digital outputs	EB 80 module with 6 M8 digital outputs + electrical supply	EB 80 module with 4 M8 analogue inputs	EB 80 module with 4 M8 analogue outputs	EB 80 module with 16 digital terminal block inputs	EB 80 module with 16 digital terminal block outputs	EB 80 module with 4 M8 analogue inputs for temperature measurement
See page B2.16	See page B2.16	See page B2.17	See page B2.17	See page B2.18	See page B2.18	See page B2.19	See page B2.19

Part included in the **ELECTRICAL CONNECTION - E** with Fieldbus

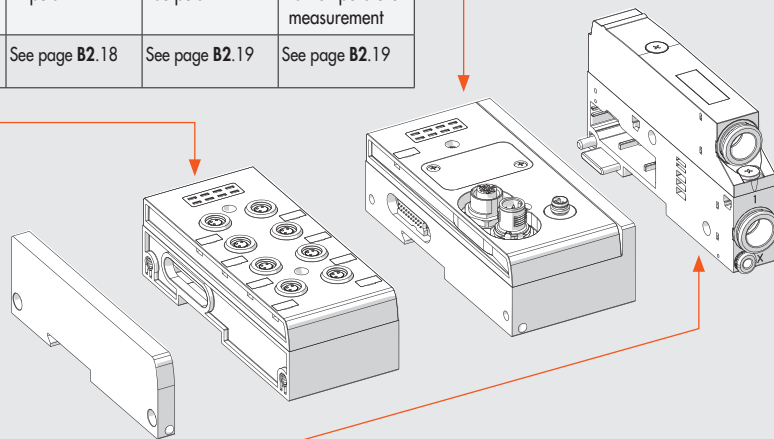

COMPRESSED-AIR SUPPLY - P

P__Z00	P__Z__	P__Z_0	P91Z90
Compressed air supply - Silenced relief	Compressed air supply - Conveyed relief	Compressed air supply - Separate reliefs	Module for electric version only
See page B2.47	See page B2.47	See page B2.47	See page B2.48

PROPORTIONAL PRESSURE REGULATOR - A

A40_Z_0	A41_Z_0
Base port 1 pass-through local outlet	Base port 1 sectioned in-series regulation
See page B2.61	See page B2.61

VALVES											
Z_ ▲	I_ ▲	W_ ▲	L_ ▲	V_	K_ ▲	O_ ▲	G_	J_	R_ +	NO	Y8
2 valvole 2/2 NC	2 valvole 3/2 NC (vale come 5/3 OC)	2 valvole 3/2 NO (vale come 5/3 PC)	3/2 NC + 3/2 NO	5/2 monostabile	5/2 bistabile	5/3 CC	3/2 NC alta portata	3/2 NO alta portata	Valvola sezionatrice di circuito	Falsa valvola	Bypass
See page B2.53	See page B2.53	See page B2.53	See page B2.53	See page B2.53	See page B2.53	See page B2.53	See page B2.54	See page B2.54	See page B2.55	See page B2.56	See page B2.56

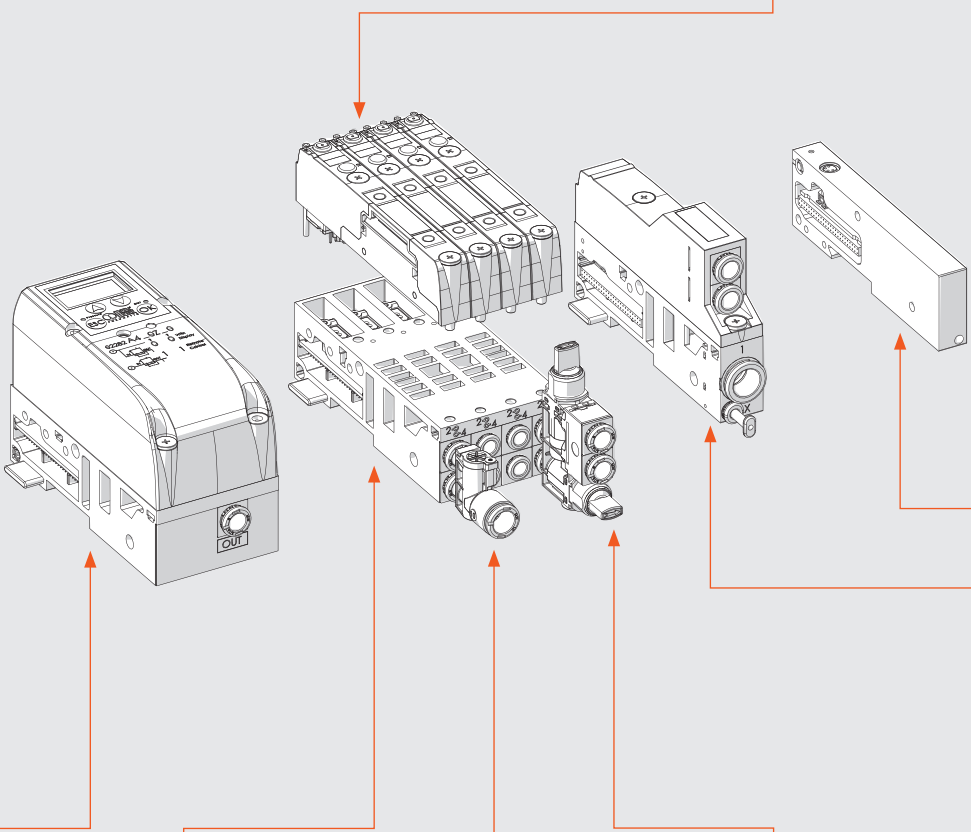

CLOSED END-PLATE - C		
C1	C2	C3
Closed end-plate for islands with multi-pole connector	Closed end-plate for islands with fieldbus	Closed end-plate for electrical connection of islands with fieldbus to additional islands
See page B2.70	See page B2.70	See page B2.70

INTERMEDIATE SUPPORT - M		
M_ _ Z0_	M_ _ Z_	M_ _ Z_ _
Intermediate module - Silenced relief	Intermediate module - Conveyed relief	Intermediate module - Separate relief
See page B2.65	See page B2.66	See page B2.67

BASES FOR VALVES - B	
B3_ _ 0	B4_ _ _ _
3-position base for valves	4-position base for valves
See page B2.50	See page B2.50

Y-FITTING
Y-fitting
See page B2.57

MULTI-FUNCTION MODULE
Fittings with pneumatic functions
See page B2.88

▲ Can only be used with 6 or 8 control bases.
+ Requires inlet port X slave synchronisation.

FIXING OPTIONS

- 1 - **Fixing on a DIN bar:** tighten the grub screws into modules E (electrical connection) and C (closed end-plate).
For islands with more than 40 valves or 5 modules, also use the additional plate code 02282R4001.
 - 2 - **Fixing on a flat surface:** use the pair of brackets code 02282R4000 and the M5x20 screws supplied.
You can choose where to position the brackets in relation to the island:
 - 2A - **Protruding brackets:** can be used to install the island + brackets unit from above. First secure the brackets to the modules E and C using the grub screws, then secure everything with M5x20 screws.
 - 2B - **Concealed brackets:** the overall dimensions of the island are reduced. First secure the brackets to the flat top with M5x20 screws, then place the island onto the brackets and lock the two grub screws provided in the modules E and C.
 - 3 - **Fixing through a wall:** use the brackets code 02282R4000. The brackets come with M6 threaded holes and can be fixed with M6 screws (not included in the supply) passing through the wall. The brackets can be fixed either protruded or concealed.
- N.B.:** Planar surfaces are required to ensure correct fixing. Avoid twisting or bending the valve units.

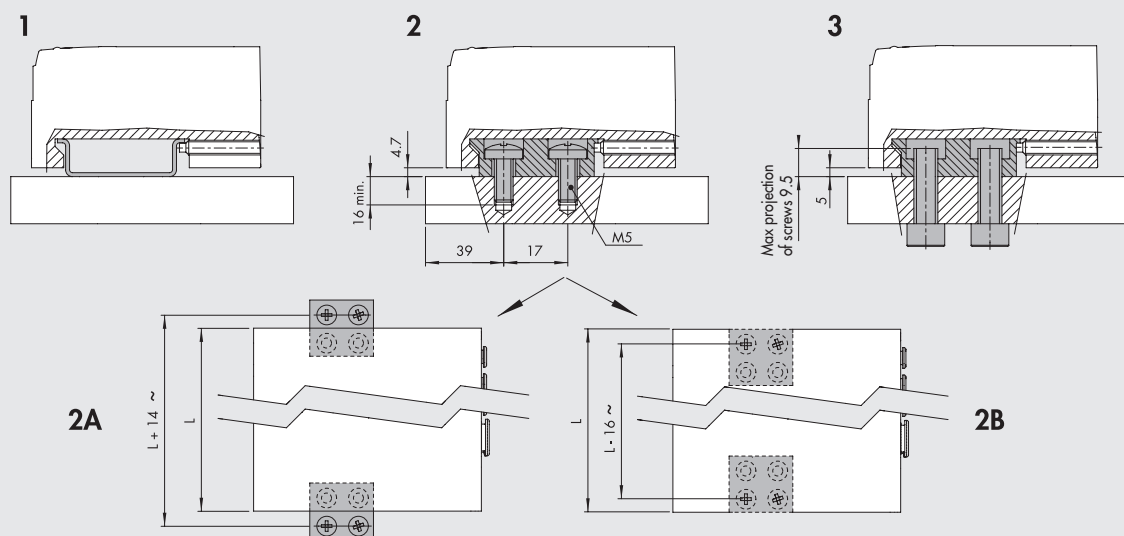

LUBRICATION



The EB 80 electro-pneumatic system is designed to run millions of cycles without the need for any lubrication. This is possible thanks to the optimisation of its components and the use of a special grease with excellent properties and NSF H1 certified. To avoid removing the grease, it is highly recommended not to lubricate the valve input and output ports and check the quality (to ISO 8573-1 class 4-7-3) of the compressed air used, which is often contaminated by particularly aggressive oils that are released by compressors and are not always compatible with the elastomers used in the valves.

SOME CHARACTERISTICS OF EB 80 SYSTEMS

HORIZONTAL MODULARITY

- Easy replacement or addition of any sub-assembly.
The locking tie rods are included in each sub-assembly.

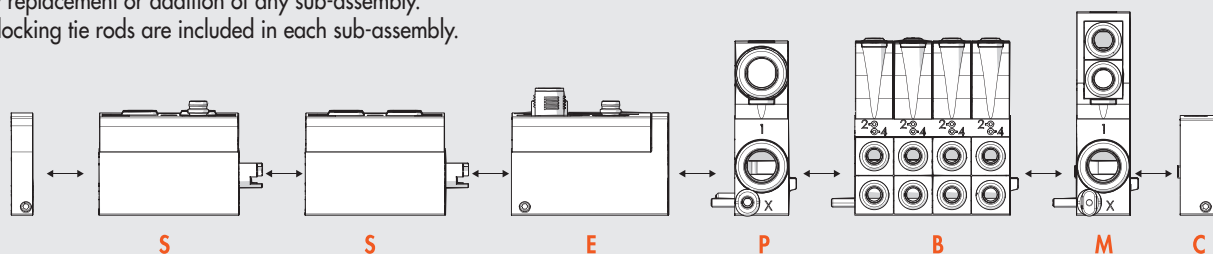

VERTICAL MODULARITY

- Easy replacement – no need to disassemble the pack – of the valves on the Bases – B and also of the top part (cover) of subsystems **S**, **E**, **P**, **M** using a single Phillips-head screwdriver.
- N.B.:** All protocols can be mounted on the base for field buses and all input or output modules can be mounted on the same base for signals.

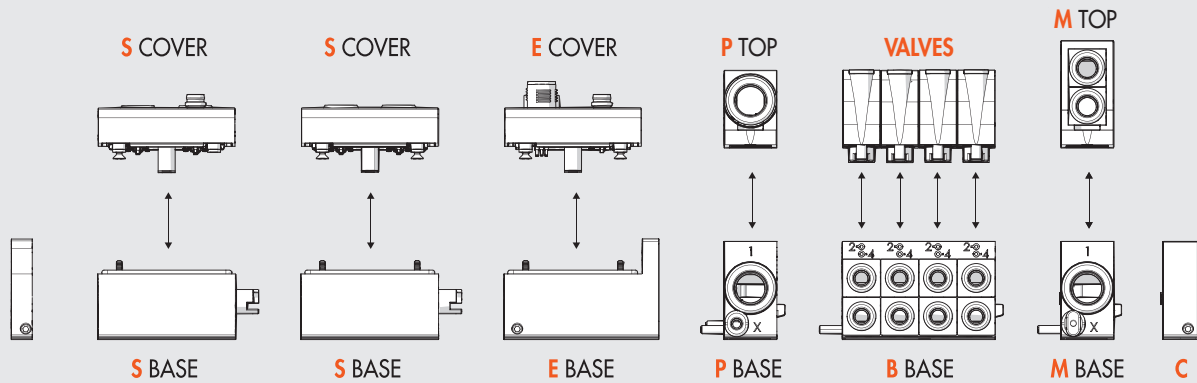

ONE SIZE FITS ALL

- Reduced dimensions
- High flow rate
- One warehouse and spares

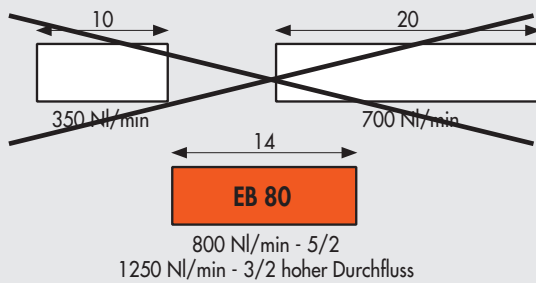

THE SAME BASE FITS BOTH MULTI-POLE CONNECTIONS AND FIELD BUSES

- Controls from multi-pole connection
- Controls from field buses
- Diagnostics

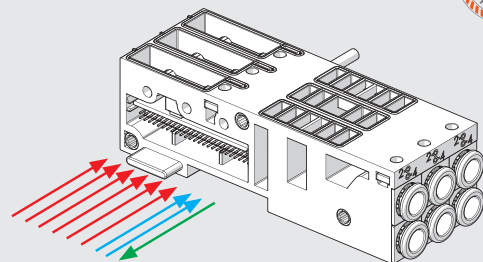

THE SAME ISLAND CAN BE SUPPLIED 10.8 - 31.2 VDC

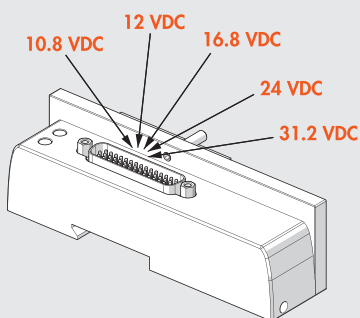

ONLY 0.3 W FOR EACH SOLENOID VALVE

- Speed-up solenoid valve control:
 - high power for a few milliseconds ensures high performance and rapid and safe switching;
 - reduced holding power resulting in reduced temperatures and energy saving.

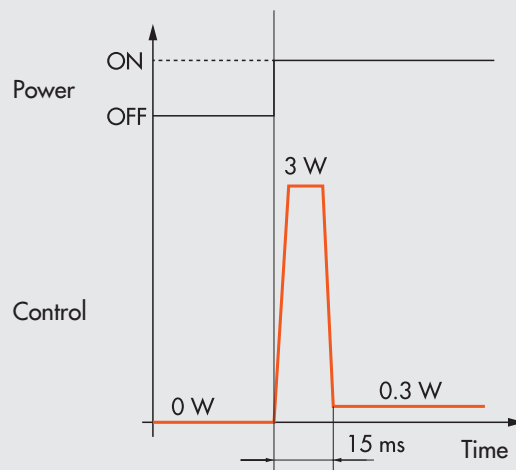

3- OR 4-POSITION BASES FOR VALVES

- Island layout options:
 - 3 1 base with 3 positions
 - 4 1 base with 4 positions
 - 5 2 bases with 3 positions and 1 dummy valve)
 - 6 2 bases with 3 positions
 - 7 1 base with 3 and 1 with 4 positions
 - 8 2 bases with 4 positions
 - ...
- Compared to single-base solutions, this configuration is advantageous because:
 - just a few bases are required for multiple positions;
 - the base is sturdy and rigid;
 - there is plenty of space to accommodate smart electronics

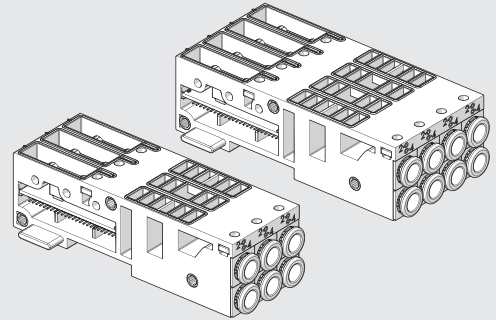

INTERCHANGEABLE CARTRIDGE FITTINGS

- For pipes \varnothing 4 (5/32"), 6, 8 (5/16"), 1/4"

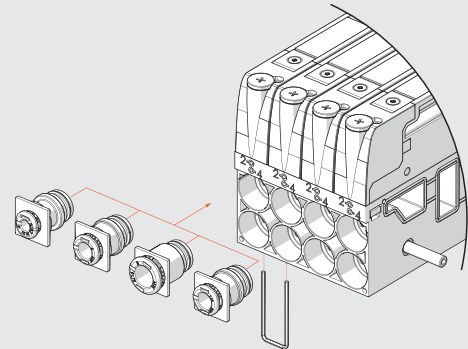

DIMENSIONS

DIMENSION OF VERSIONS WITH MULTI-POLE CONNECTION

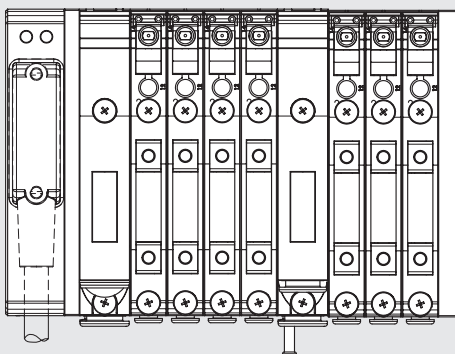
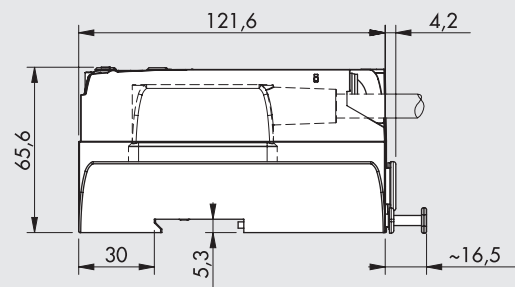
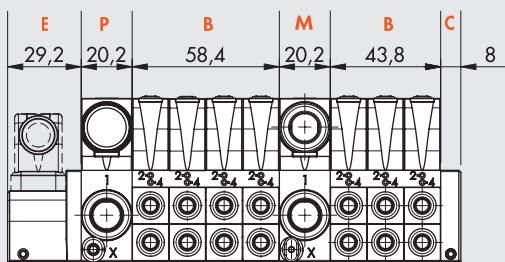

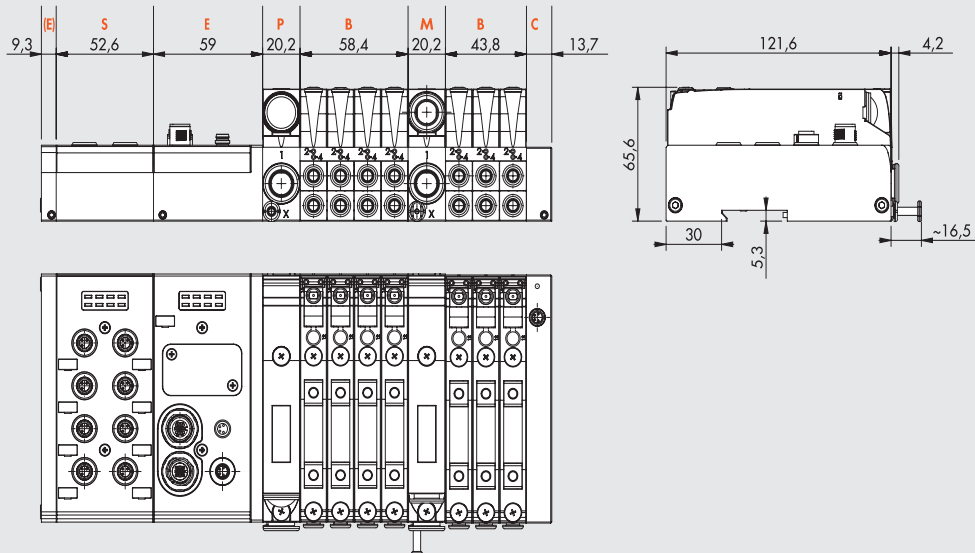
DIMENSION OF VERSIONS WITH FIELD BUS OR ADDITIONAL CONNECTION

DESCRIPTION

A complete system has a compound **description** of all its subsystems listed in sequence from left to right, as shown below. The abbreviation of each subsystem is obtained by taking the code and omitting the first digits 02282. For example: the digital 8-input signal module is identified with code 02282S01; only write S01 in the description.

The abbreviation of each base for valves consists of:

Abbreviation of the Base	Manual valve control	Type of valves
Obtained from the code, after removing 02282	0 = monostable 1 = bistable	Valves Dummy valve Bypass
Example 4-position base, 8 solenoid pilots, Ø 6 pipe; code 02282B4086666	Monostable	2 monostable 5/2 valves - V 1 double 3/2 NO - W 1 dummy valve - F
Abbreviation B4086666	0	VVWF

The description is therefore a sequence of this type:

EB 80	- S _ _	- E _ _ _	- P _ _ _ _	- B _ _ _ _ _ _ _ _	- M _ _ _ _ _	- C _
EB 80 system	Signal module (if present)	Electrical connection	Compressed air supply	Base for valves (as many as there are) with normal or dummy	Intermediate (if present)	Closed end-plate
For the codes:	see page B2.20	see page B2.24	see page B2.48	see page B2.51 and B2.56	see page B2.68	see page B2.71

Example:

EB 80-S01-E0EN-P3XZ00-B40866660VWKN-M300Z30-B30388800VVN-C2

EB 80	- S01	- E0EN	- P3XZ00	- B40866660VWKN	- M300Z30	- B30388800VVN	- C2
EB 80 system	Signal module complete 8 M8 digital inputs	Electrical connection EtherNet/IP	Compressed air supply - fitting Ø 12 - pilot servo Ø 4 - silenced relief	Base for valves - 4 positions - 8 controls - fittings for pipe Ø 6 - manual monostable control - 5/2 monostable valve - 2 3/2 NO valves - bistable 5/2 valve - dummy valve	Intermediate - fittings for pipe Ø 12 - through ports - without supplementary power supply	Base - 3 positions - 3 controls - fittings for pipe Ø 8 - manual monostable control - 5/2 monostable valve - 5/2 monostable valve - dummy valve	Closed end-plate for valve Island with field bus

Endless number of EB 80 systems can be obtained and their description is variable in length, which can be very extended. The actual ordering CODE of an EB 80 system is created by Metal Work S.p.a. with a limited number of characters. The ordering code is not explicative. The description only is univocal, complete and explicative.

EB 80 INDUSTRY 4.0

The new advanced EB 80 diagnostic functions, known as EB 80 I4.0, provide a powerful analysis tool for traditional maintenance operations, ensuring the safe, reliable and lasting operation of production units.

They are available for all electrical connections with fieldbuses and bases marked I4.0, with advanced diagnostics integrated in accordance with Industry 4.0 philosophy.

These functions use the original EB 80 diagnostics, integrating them with the ability of the station itself to control IOs.

They re-organise and optimise maintenance management by developing predictive maintenance in order to:

- predict faults;
- intervene early to avoid system downtime;
- have all information on equipment operation available in real time;
- monitor component end-of-lifetime;
- optimise warehouse spare parts management.

This makes it possible to turn the data collected into concrete actions using standard EB 80 stations without needing additional modules.

Description of EB 80 I4.0 functions:

- System data:
 - EB 80 system startup counter;
 - supply alert counter.
- Valve data. Each valve base for each solenoid valve permanently stores the following information:
 - cycle counter;
 - counter for total solenoid valve excitation time;
 - activation of a flag to signal average lifetime exceeded;
 - short circuit alert counter;
 - open circuit alert counter.
- Electropneumatic system control functions (data updated with each cycle):
 - measurement of the delay between activating the solenoid valve "A" and actuator movement commencing via the signal of sensor "B", with delays that exceed the limit flagged;
 - measurement of actuator movement time using two linked sensors "B" and "C", with exceeded time limits flagged;
 - measurement of the delay between deactivating the solenoid valve "A" (or activating a second valve) and actuator return commencing via the signal of sensor "B", with exceeded time limits flagged;
 - measurement of actuator return time using two linked sensors "B" and "C", with exceeded time limits flagged;
 - counter for actuator range of motion.

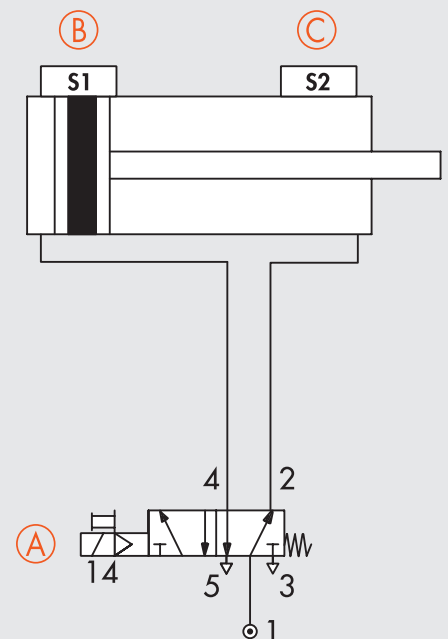
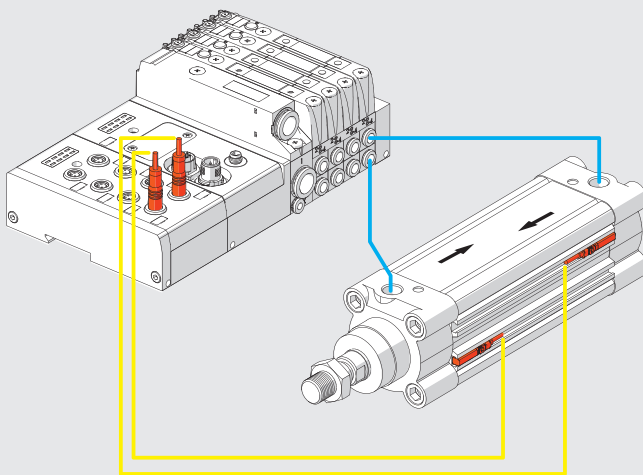

Electrical connection modules can be used to complement the EB 80 with the main field buses available in the market. In this way, the control system (generally a PLC) can handle in real time the behaviour of the solenoid valve island, including signal modules.

With the introduction of the I4.0 version, the field bus connection modules also send to the network the historical and diagnostic data relating to the behaviour of the island (such as the number of cycles for each solenoid pilot, total activation time and alarms) and the controlled pneumatic circuit (such as the delay times in sensor switching and actuator activation times).

This data is also sent to the control system and can be handled differently depending on the situation: in some cases, it can be used in real time, like in the case of fault alarms; in other cases, it can be sent to a storage local unit or one remotely controlled on a cloud server, and is analysed in a subsequent stage; in other cases, the alarms can be sent to a teleservice station that can monitor the state of the system remotely.

